

PRELIMINARY PLANS

IT IS A VIOLATION OF LAW FOR ANY PERSON, UNLESS THEY ARE ACTING UNDER THE DIRECT DIRECTION OF A LICENSED PROFESSIONAL ENGINEER, ARCHITECT, LANDSCAPE ARCHITECT, OR LAND SURVEYOR, TO ALTER AN ITEM IN ANY WAY. IF AN ITEM BEARING THE STAMP OF A LICENSED PROFESSIONAL IS ALTERED, THE ALTERING ENGINEER, ARCHITECT, LANDSCAPE ARCHITECT, OR LAND SURVEYOR SHALL STAMP THE DOCUMENT AND INCLUDE THE NOTATION "ALTERED BY" FOLLOWED BY THEIR SIGNATURE, THE DATE OF SUCH ALTERATION, AND A SPECIFIC DESCRIPTION OF THE ALTERATION.

CITY OF PORTSMOUTH CITY OF PORTSMOUTH, NEW HAMPSHIRE			
PEVERLY HILL ROAD RECONSTRUCTION			
TYPICAL SECTIONS			
SCALE: AS SHOWN	DESIGN: MAH	TS-01 2 OF 61	
DRAWN: MJF	PROJECT: 18082.01		
CHECKED: JWS	DATE: XX/XX/2018		

McFarland Johnson
 53 REGIONAL DRIVE
 CONCORD, NH 03301

REV	DATE	DESCRIPTION	BY

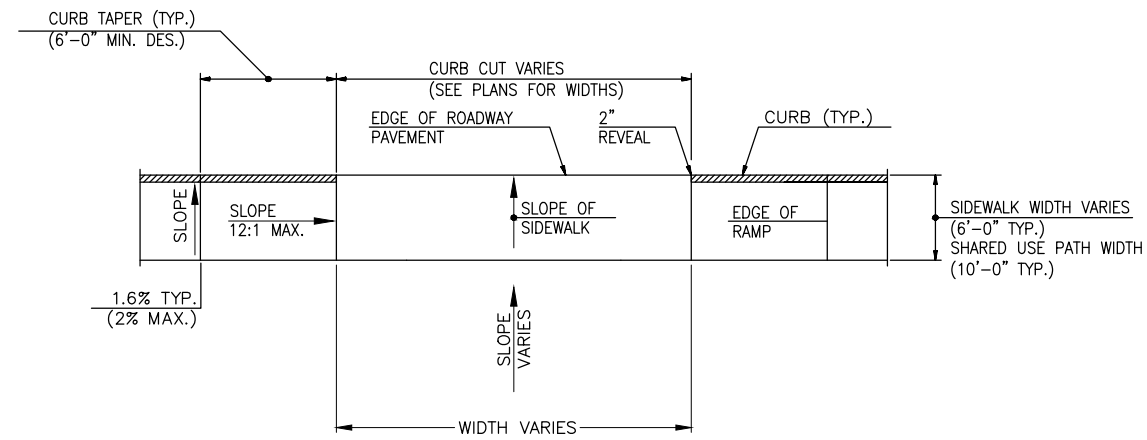

PLAN VIEW WITH SIDEWALK RAMP
N.T.S.

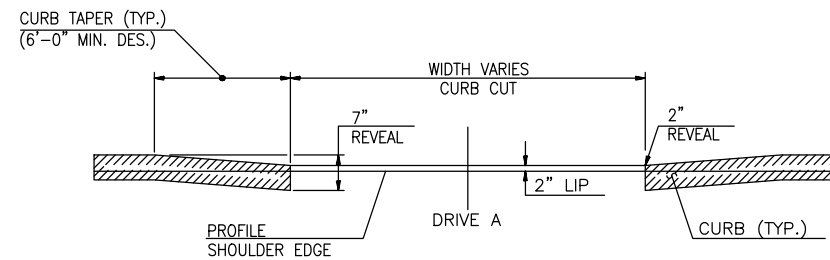

END VIEW
N.T.S.

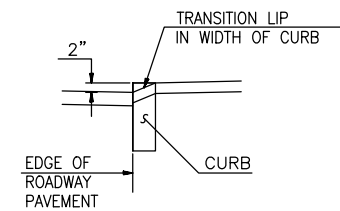

LIP DETAIL

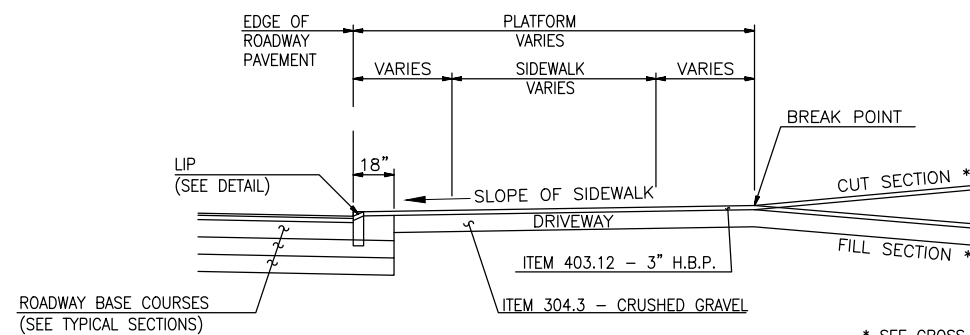

* SEE CROSS SECTIONS FOR ADDITIONAL INFORMATION ON DRIVEWAY SLOPES BEYOND SIDEWALK

TYPICAL URBAN CURBED DRIVE IN CUT/FILL SECTION
N.T.S.

PRELIMINARY PLANS

IT IS A VIOLATION OF LAW FOR ANY PERSON, UNLESS THEY ARE ACTING UNDER THE DIRECT DIRECTION OF A LICENSED PROFESSIONAL ENGINEER, ARCHITECT, LANDSCAPE ARCHITECT, OR LAND SURVEYOR, TO ALTER AN ITEM IN ANY WAY. IF AN ITEM BEARING THE STAMP OF A LICENSED PROFESSIONAL IS ALTERED, THE ALTERING ENGINEER, ARCHITECT, LANDSCAPE ARCHITECT, OR LAND SURVEYOR SHALL STAMP THE DOCUMENT AND INCLUDE THE NOTATION "ALTERED BY" FOLLOWED BY THEIR SIGNATURE, THE DATE OF SUCH ALTERATION, AND A SPECIFIC DESCRIPTION OF THE ALTERATION.

CITY OF PORTSMOUTH
CITY OF PORTSMOUTH, NEW HAMPSHIRE
PEVERLY HILL ROAD RECONSTRUCTION
CURBING AND DRIVEWAY DETAILS

McFarland Johnson
53 REGIONAL DRIVE
CONCORD, NH 03301

SCALE: AS SHOWN	DESIGN: MAH	DT-01 17 OF 61
DRAWN: MJF	PROJECT: 18082.01	
CHECKED: JWS	DATE: XX/XX/2018	

REV	DATE	DESCRIPTION	BY

GENERAL NOTES:

- THESE SHEETS ARE IN ACCORDANCE WITH THE AMERICANS WITH DISABILITIES ACT (ADA), AND THE REQUIREMENTS OF THE 2011 PROPOSED ACCESSIBILITY GUIDELINES FOR PEDESTRIAN FACILITIES IN THE PUBLIC RIGHT OF WAY (PROWAG).
- NOT ALL FACILITIES CAN BE CONSTRUCTED TO MEET THE DESIGN STANDARDS. FACILITIES THAT CANNOT BE CONSTRUCTED TO MEET THE DESIGN STANDARDS SHALL BE CONSTRUCTED TO MEET THE STANDARDS TO THE GREATEST EXTENT PRACTICABLE. NONSTANDARD FEATURES SHALL BE DOCUMENTED ON TECHNICAL INFEASIBILITY FORM AND SUBMITTED TO NHDOT ADA COORDINATOR FOR APPROVAL.
- TO CHECK FIELD LAYOUT ALL SLOPES AND GRADES SHALL BE MEASURED WITH A DIGITAL LEVEL USING AT LEAST TWO READINGS. WHERE THE READINGS VARY, THE MEASUREMENTS SHALL BE AVERAGED. GRADE (RUNNING SLOPE) SHALL BE MEASURED ALONG THE CENTERLINE AND OFFSET 1.00' TO 1.50' FROM THE CENTERLINE. CROSS SLOPES SHALL BE MEASURED PERPENDICULAR TO CENTERLINE AT 5.00' TO 10.00' INTERVALS.
- GRADES (RUNNING SLOPES) ARE MEASURED IN THE DIRECTION OF PEDESTRIAN TRAVEL. CROSS SLOPES ARE MEASURED PERPENDICULAR TO THE DIRECTION OF PEDESTRIAN TRAVEL.
- JOINTS BETWEEN SIDEWALKS, CURB RAMPS, TURNING SPACES AND ROADWAYS SHALL BE FLUSH AND FREE FROM ABRUPT VERTICAL CHANGES GREATER THAN 1/4". VERTICAL SURFACE DISCONTINUITIES BETWEEN 1/4" AND 1/2" SHALL BE BEVELED WITH A SLOPE NOT STEEPER THAN 2:1. THE BEVEL SHALL BE APPLIED ACROSS THE ENTIRE JOINT. SEE DETAIL ON SHEET 9 OF 9.
- SIDEWALKS ARE CONNECTED TO ROADWAYS BY EITHER BLENDED TRANSITIONS OR CURB RAMPS. BLENDED TRANSITIONS ARE CONNECTIONS BETWEEN THE SIDEWALK LEVEL AND THE ROADWAY LEVEL THAT HAVE A MAXIMUM GRADE (RUNNING SLOPE) OF 5%, AND TRANSITIONS GREATER THAN 5% ARE CONSIDERED CURB RAMPS.
- CURB RAMPS AND BLENDED TRANSITIONS MAY REQUIRE THE INSTALLATION OF DETECTABLE WARNINGS. SEE ADDITIONAL "DETECTABLE WARNING DEVICE NOTES" ON THIS SHEET, AND DETAILS ON SHEET 6 OF 10 FOR DIMENSIONS, ORIENTATION AND INSTALLATION.
- VERTICAL ALIGNMENT SHALL BE GENERALLY PLANAR. GRADE BREAKS WITHIN THE PEDESTRIAN ACCESS ROUTE SHALL BE PERPENDICULAR TO THE DIRECTION OF TRAVEL AND SHALL NOT BE ROUNDED.
- THE CROSS SLOPE OF PEDESTRIAN ACCESS ROUTES (PAR) SHALL BE 2% MAXIMUM. THE FOLLOWING EXCEPTIONS ARE ALLOWED:
 - WHERE PEDESTRIAN CROSSINGS ARE PROVIDED AT INTERSECTIONS WITHOUT YIELD OR STOP CONTROL OR WHERE THERE IS ANY TRAFFIC SIGNAL, THE CROSS SLOPE OF A PEDESTRIAN ACCESS ROUTE CONTAINED WITHIN A CROSSING SHALL BE 5% MAXIMUM.
 - WHERE MIDBLOCK PEDESTRIAN CROSSINGS ARE PROVIDED, THE CROSS SLOPE OF A PEDESTRIAN ACCESS ROUTE CONTAINED WITHIN A MIDBLOCK CROSSING SHALL BE PERMITTED TO EQUAL THE STREET OR HIGHWAY GRADE.
- THE MINIMUM CLEAR WIDTH FOR PEDESTRIAN ACCESS ROUTES IS 4.00', EXCLUSIVE OF THE CURB. WHEN WALKWAY WIDTHS ARE LESS THAN 5.00', 5.00' x 5.00' PASSING SPACES, OR A FEATURE OF EQUAL OR GREATER DIMENSIONS (E.G., DRIVEWAYS) THAT MEET THE SLOPE CRITERIA, SHALL BE PROVIDED AT A MAXIMUM INTERVAL OF 200'. EXISTING DRIVEWAYS AND STREET CROSSING MAY ALSO SERVE AS PASSING SPACES.
- THE BUFFER ZONE IS A PHYSICAL DISTANCE SEPARATING THE PEDESTRIAN ACCESS ROUTE FROM THE VEHICLE TRAVELED WAY. THE BUFFER ZONE MAY BE PLANTED OR PAVED.
- WHEN CROSSING DRIVEWAYS, THE WORK SHALL BE IN CONFORMANCE WITH NHDOT DRIVEWAY DETAILS SHEET. THE CROSS SLOPE ACROSS DRIVEWAYS SHALL BE 2% MAXIMUM.
- FOR ACCESSIBLE PEDESTRIAN SIGNAL PUSH BUTTONS, SEE DETAILS ON SHEET 8 OF 9.
- FOR RAMP COUNTER SLOPE REQUIREMENTS, SEE DETAILS ON SHEET 9 OF 9.

CURB RAMP NOTES:

- THE MINIMUM WIDTH OF A CURB RAMP SHALL BE 4.00'.
- THE FULL WIDTH OF THE RAMP OR LANDING SHALL BE CONTAINED WITHIN THE PAVEMENT MARKINGS AT MARKED CROSSWALKS.
- CURB RAMPS ARE NOT REQUIRED IN LOCATIONS WHERE THERE IS NO ACCESSIBLE PEDESTRIAN ACCESS ROUTE. UNLESS IT IS SERVING AS A LANDING FOR A PEDESTRIAN SIGNAL.
- THE GRADE (RUNNING SLOPE) OF A CURB RAMP SHALL BE A MAXIMUM OF 8.3%.
- WHERE EXISTING CONDITIONS DO NOT ALLOW THE CONSTRUCTION OF A CURB RAMP WITH A GRADE (RUNNING SLOPE) OF 8.3% OR LESS, THE RAMP LENGTH SHALL NOT BE REQUIRED TO EXCEED 15.00'.
- THE CROSS SLOPE OF THE CURB RAMP SHALL BE AS FLAT AS POSSIBLE AND STILL PROVIDE POSITIVE DRAINAGE. THE CROSS SLOPE OF A CURB RAMP 2% MAXIMUM. SEE NOTE 9 FOR EXCEPTIONS. WHERE THE EXISTING ROADWAY GRADE EXCEEDS 2%, THE CURB RAMP MAY BE WARPED ACCORDING TO THE DETAIL ON SHEET 9 OF 9 TO TIE INTO THE ROADWAY GRADE.
- RAMP SIDE TREATMENT OPTIONS ARE DETAILED ON SHEET 7 OF 9 FOR USE WITHIN THE BUFFER ZONE, WHERE A PEDESTRIAN CIRCULATION PATH CROSSES THE CURB RAMP. FLARED SIDES SHALL BE INSTALLED WITH A SLOPE OF 10% MAXIMUM. THE SLOPE OF FLARED SIDES IS MEASURED PARALLEL TO THE CURB LINE. (ALSO SEE CURB RAMP CONFIGURATION TYPE 7 ON SHEET 3 OF 9.)
- THE BACKSIDE OF A PARALLEL RAMP SHOULD BE GRADED TO MATCH EXISTING TERRAIN, UNLESS OTHERWISE SHOWN IN THE CONTRACT DOCUMENTS. WHERE GRADING IS NOT FEASIBLE DUE TO LIMITED ROW OR PHYSICAL CONSTRAINTS, A BACK CURB MAY BE INSTALLED. SEE DETAILS ON SHEET 7 OF 9.

TURNING SPACE AND CLEAR SPACE NOTES:

- WHERE A CHANGE IN DIRECTION IS REQUIRED TO UTILIZE A CURB RAMP, A TURNING SPACE SHALL BE PROVIDED AT THE BASE AND/OR THE TOP OF CURB RAMP AS APPLICABLE. TURNING SPACES SHALL BE PERMITTED TO OVERLAP CLEAR SPACES.
- WHERE THERE ARE NO VERTICAL CONSTRAINTS AT THE BACK OF SIDEWALK, (E.G., VERTICAL CURB, BUILDINGS, FENCES) THE TURNING SPACE DIMENSIONS SHALL BE 4.00' x 4.00' MINIMUM. WHERE THE TURNING SPACE IS CONSTRAINED AT THE BACK OF SIDEWALK, THE TURNING SPACE SHALL BE 4.00' x 5.00' MINIMUM. THE 5.00' DIMENSION SHALL BE PROVIDED PERPENDICULAR TO THE CONSTRAINT.
- TURNING SPACE MAXIMUM CROSS SLOPE IS 2% IN ANY DIRECTION.
- BEYOND THE BOTTOM GRADE BREAK, A CLEAR SPACE OF 4.00' x 4.00' MINIMUM SHALL BE PROVIDED WITHIN THE WIDTH OF THE PEDESTRIAN CROSSWALK, AND OUTSIDE THE PARALLEL VEHICLE TRAVEL LANE. THE CLEAR SPACE MAY OVERLAP TURNING SPACES, DETECTABLE WARNING SURFACES, AND DROP CURBS.

DETECTABLE WARNING DEVICE NOTES:

- DETECTABLE WARNING DEVICES (DWD) SHALL BE PROVIDED AT THE FOLLOWING LOCATIONS ON PEDESTRIAN ACCESS ROUTES:
 - CURB RAMPS AT PEDESTRIAN CROSSINGS.
 - PEDESTRIAN REFUGE ISLANDS (WHERE THE LENGTH OF THE PEDESTRIAN ACCESS ROUTE ACROSS THE REFUGE ISLAND IS GREATER THAN OR EQUAL TO 6.00'). SEE SHEET 8 OF 9.
 - PEDESTRIAN AT-GRADE RAIL CROSSINGS NOT LOCATED WITHIN A STREET OR HIGHWAY.
 - DRIVEWAY CROSSINGS WITH NHDOT APPROVED AND MAINTAINED SIGNALS, YIELD OR STOP CONTROL. DETECTABLE WARNING DEVICES SHALL NOT BE PROVIDED AT CROSSINGS OF UNCONTROLLED DRIVEWAY APRONS.
- SOME DETECTABLE WARNING PRODUCTS REQUIRE A CONCRETE BORDER FOR PROPER INSTALLATION. IF REQUIRED, THE BORDER SHALL NOT EXCEED 2" IN WIDTH OR 6" ALONG ROADWAY EDGE/CURB. THE BORDER DIMENSION SHALL BE MEASURED FROM THE INSIDE EDGE OF THE RADIUS.
- THE DETAILS PROVIDED ARE NOT DRAWN TO SCALE. THE QUANTITY OF DOMES DEPICTED ON THE DETECTABLE WARNING DEVICE DETAIL IS FOR ILLUSTRATION ONLY. THE SIZE OF THE DETECTABLE WARNING FIELD SHALL BE 2.00' MINIMUM IN THE DIRECTION OF TRAVEL AND SHALL EXTEND THE FULL WIDTH OF THE CURB RAMP OR FLUSH SURFACE, EXCLUDING ANY FLARED SIDES. THE WIDTH OF THE DETECTABLE WARNING FIELD INCLUDES A CONCRETE BORDER, IF PROVIDED. PLACEMENT AND ORIENTATION SHALL BE IN COMPLIANCE WITH THE DETAILS.
- ON SLOPES OF 5% OR GREATER, THE ROWS OF DOMES SHALL BE ALIGNED TO BE PERPENDICULAR OR RADIAL TO THE LOWER GRADE BREAK ON THE RAMP RUN. WHERE DOMES ARE ARRAYED RADIALLY THEY MAY DIFFER IN DOME DIAMETER AND CENTER-TO-CENTER SPACING WITHIN THE RANGES SPECIFIED ON SHEET 9. ON SLOPES LESS THAN 5%, DOME ORIENTATION IS LESS CRITICAL AND MAY DIFFER FROM PERPENDICULAR OR RADIAL ALIGNMENT TO THE GRADE BREAK.
- THE DETECTABLE WARNING SURFACES SHALL CONTRAST VISUALLY WITH ADJACENT GUTTER, STREET OR HIGHWAY, OR PEDESTRIAN ACCESS ROUTE SURFACE.
- DETECTABLE WARNING PANELS SHALL BE CAST IRON WITH NO SURFACE COATING AND SHALL BE ALLOWED TO TRANSITION TO THEIR NATURAL PATINA.

DEFINITION OF TERMS:

LANDING: A 4.00' x 4.00' CLEAR SPACE WITH A 2% SLOPE OR LESS IN ALL DIRECTIONS.

MAXIMUM EXTENT FEASIBLE: ALL CHANGES THAT ARE POSSIBLE ARE MADE TO COMPLY WITH ACCESSIBILITY STANDARDS.

PEDESTRIAN ACCESS ROUTE (PAR): A CONTINUOUS AND UNOBSTRUCTED PATH OF TRAVEL PROVIDED FOR PEDESTRIANS WITH DISABILITIES WITHIN OR CONINCIDING WITH A PEDESTRIAN CIRCULATION PATH. PAR SHALL BE 4' W MIN. (EXCLUDING CURBING), 2% MAX. CROSS SLOPE AND 1/4" OR LESS VERTICAL DISCONTINUITY.

TECHNICAL INFEASIBILITY: EXISTING PHYSICAL OR SITE CONSTRAINTS THAT PROHIBIT MODIFICATIONS OR ADDITIONS OF ELEMENTS, SPACES OR FEATURES TO COMPLY WITH MINIMUM ACCESSIBILITY REQUIREMENTS.

INDEX OF SHEETS

1 OF 9	INDEX OF SHEETS AND GENERAL NOTES
2 OF 9	CURB RAMP CONFIGURATIONS TYPE 1 - 5
3 OF 9	CURB RAMP CONFIGURATIONS TYPE 6 - 7
4 OF 9	CURB RAMP CONFIGURATIONS TYPE 8 - 11
5 OF 9	SLIP RAMP, SIDEWALK TO SHOULDER TRANSITION, ACCESS ISLAND
6 OF 9	DETECTABLE WARNING DEVICE PLACEMENT OPTIONS
7 OF 9	RAMP SIDE CONFIGURATIONS AND BACK TREATMENTS
8 OF 9	RR X-INGS, ROUNDABOUTS, PEDESTRIAN BUTTONS
9 OF 9	DETECTABLE WARNING DEVICE, TRUNCATED DOMES, MISCELLANEOUS DETAILS

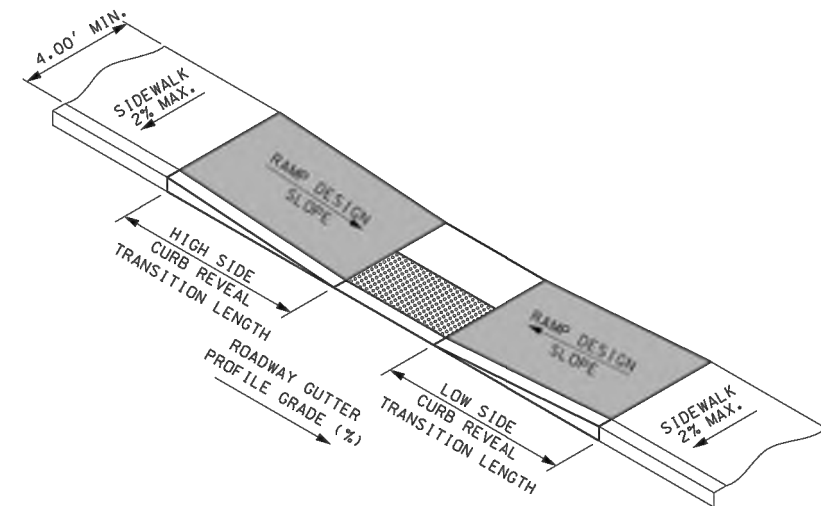

CURB REVEAL (INCHES)	ROADWAY PROFILE GRADE (%)	Minimum Transition Length Required (FT)						
		7	6	5	4	3	2	1
Low Side Transition Length	-10%	5.0	5.0	5.0	5.0	5.0	5.0	5.0
	-9%	5.0	5.0	5.0	5.0	5.0	5.0	5.0
	-8%	5.0	5.0	5.0	5.0	5.0	5.0	5.0
	-7%	5.0	5.0	5.0	5.0	5.0	5.0	5.0
	-6%	5.0	5.0	5.0	5.0	5.0	5.0	5.0
	-5%	5.0	5.0	5.0	5.0	5.0	5.0	5.0
	-4%	5.1	5.0	5.0	5.0	5.0	5.0	5.0
	-3%	5.6	5.0	5.0	5.0	5.0	5.0	5.0
	-2%	6.1	5.3	5.0	5.0	5.0	5.0	5.0
	-1%	6.9	5.9	5.0	5.0	5.0	5.0	5.0
High Side Transition Length	0%	7.8	6.7	5.6	5.0	5.0	5.0	5.0
	1%	9.0	7.7	6.4	5.1	5.0	5.0	5.0
	2%	10.6	9.1	7.6	6.1	5.0	5.0	5.0
	3%	13.0	11.1	9.3	7.4	5.6	5.0	5.0
	4%	15.0	14.3	11.9	9.5	7.1	5.0	5.0
	5%	15.0	15.0	15.0	13.3	10.0	6.8	5.0
	6%	15.0	15.0	15.0	15.0	15.0	11.3	9.3
	7%	15.0	15.0	15.0	15.0	15.0	15.0	15.0
	8%	15.0	15.0	15.0	15.0	15.0	15.0	15.0
	9%	15.0	15.0	15.0	15.0	15.0	15.0	15.0
10%	15.0	15.0	15.0	15.0	15.0	15.0	15.0	

THIS TABLE REPRESENTS THE MINIMUM LENGTH OF CURB RAMP TRANSITION BASED ON THE EXISTING ROADWAY PROFILE GRADE AND THE CURB REVEAL AT FULL HEIGHT ALONG THE SIDEWALK. THE MINIMUM TRANSITION LENGTH REQUIRED IS BASED ON 7.5% SLOPE AND INDICATED CURB REVEAL.

TREATMENT KEY LEGEND

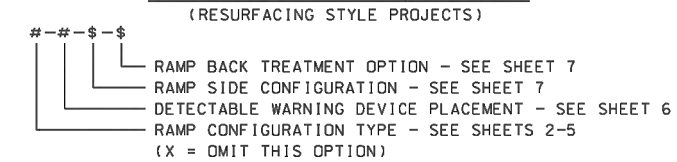

PRELIMINARY PLANS

IT IS A VIOLATION OF LAW FOR ANY PERSON, UNLESS THEY ARE ACTING UNDER THE DIRECT DIRECTION OF A LICENSED PROFESSIONAL ENGINEER, ARCHITECT, LANDSCAPE ARCHITECT, OR LAND SURVEYOR, TO ALTER AN ITEM IN ANY WAY. IF AN ITEM BEARING THE STAMP OF A LICENSED PROFESSIONAL IS ALTERED, THE ALTERING ENGINEER, ARCHITECT, LANDSCAPE ARCHITECT, OR LAND SURVEYOR SHALL STAMP THE DOCUMENT AND INCLUDE THE NOTATION "ALTERED BY" FOLLOWED BY THEIR SIGNATURE, THE DATE OF SUCH ALTERATION, AND A SPECIFIC DESCRIPTION OF THE ALTERATION.

CITY OF PORTSMOUTH
CITY OF PORTSMOUTH, NEW HAMPSHIRE

PEVERLY HILL ROAD RECONSTRUCTION

SIDEWALK DETAILS (SHEET 1 OF 9)

SCALE: ----	DESIGN: MAH	DT-02 ----OF 61
DRAWN: MJF	PROJECT: 18082.01	
CHECKED: JWS	DATE: XX/XX/2018	

McFarland Johnson

53 REGIONAL DRIVE
CONCORD, NH 03301

REV	DATE	DESCRIPTION	BY

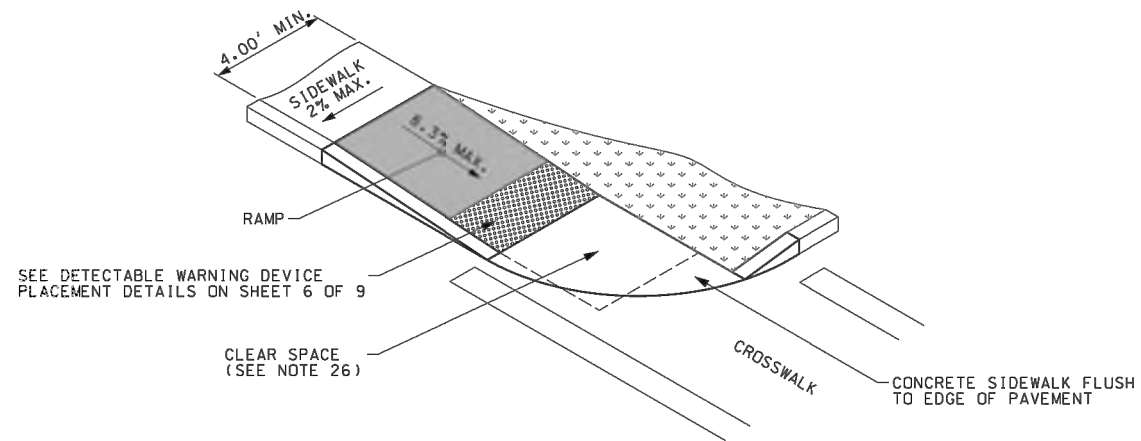

TYPE 1

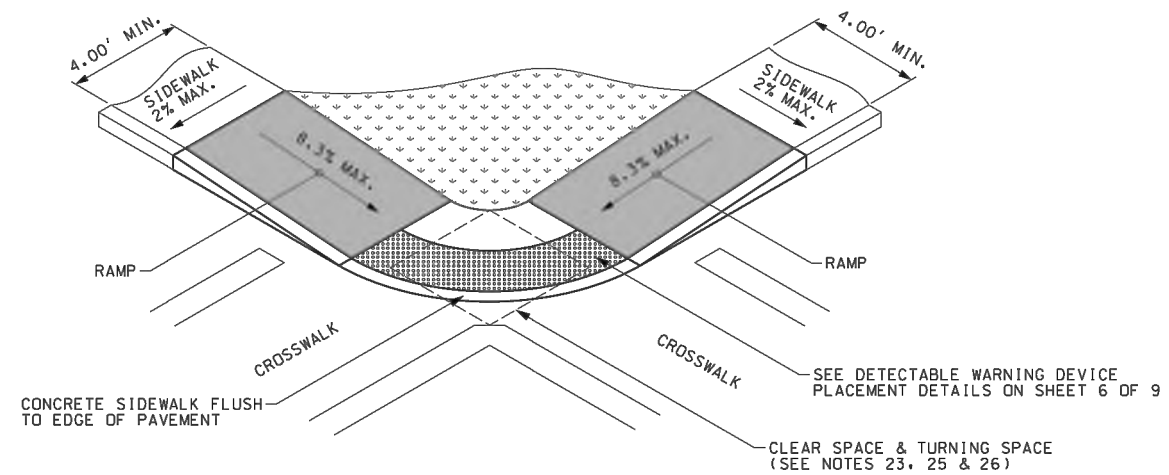

TYPE 4
NOT FOR NEW DESIGNS - RETROFITS ONLY

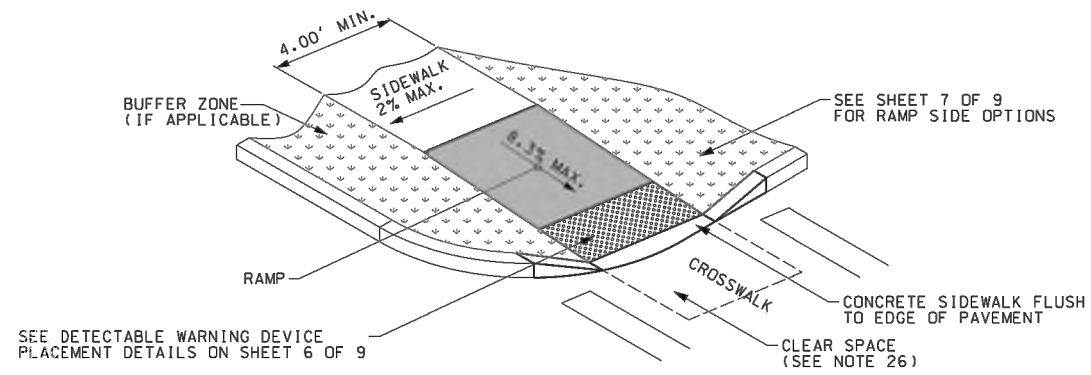

TYPE 2

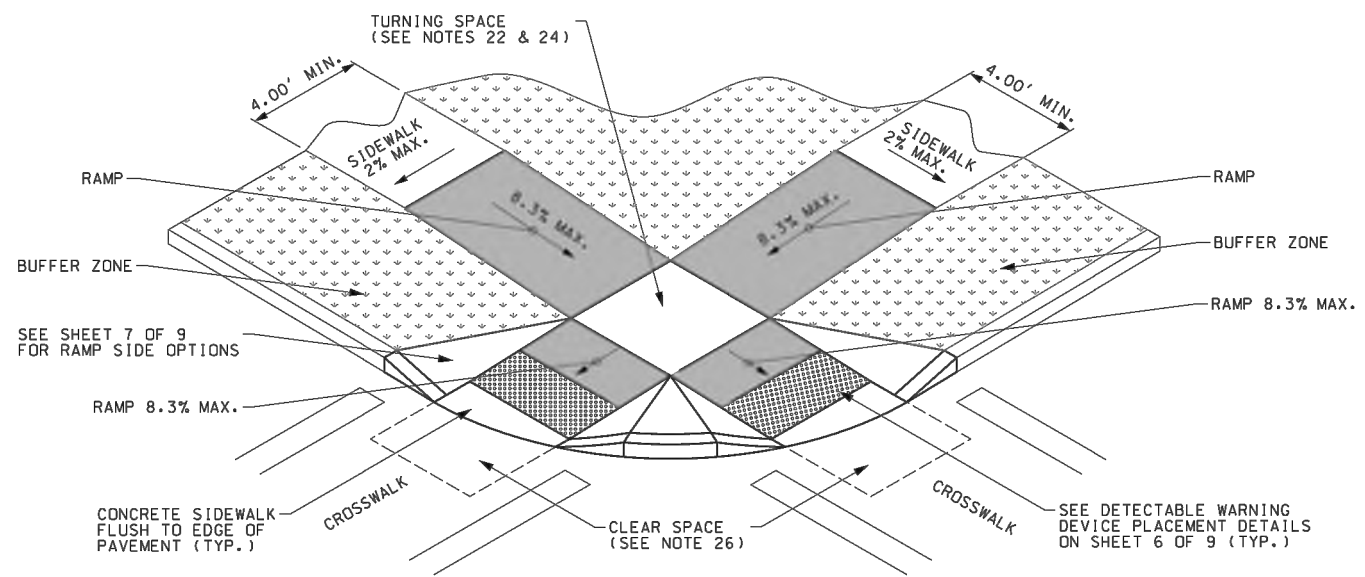

TYPE 5

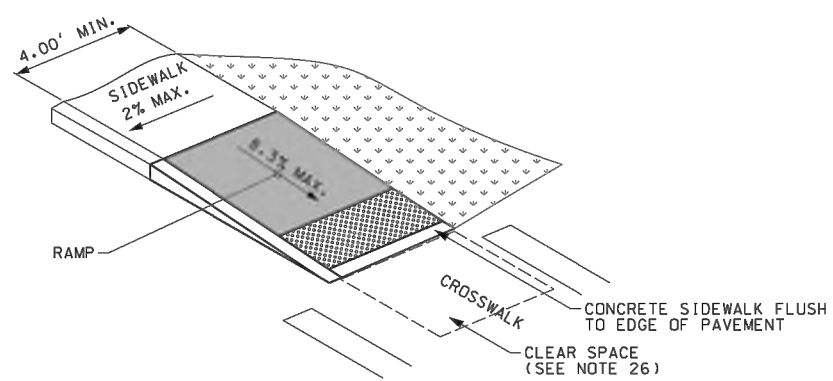

TYPE 3

CURB RAMP CONFIGURATIONS

NOTE:
ALL NOTES REFERENCED ON THIS SHEET CAN BE FOUND ON SIDEWALK CURB RAMP DETAILS, SHEET 1 OF 9.

PRELIMINARY PLANS

IT IS A VIOLATION OF LAW FOR ANY PERSON, UNLESS THEY ARE ACTING UNDER THE DIRECT DIRECTION OF A LICENSED PROFESSIONAL ENGINEER, ARCHITECT, LANDSCAPE ARCHITECT, OR LAND SURVEYOR, TO ALTER AN ITEM IN ANY WAY. IF AN ITEM BEARING THE STAMP OF A LICENSED PROFESSIONAL IS ALTERED, THE ALTERING ENGINEER, ARCHITECT, LANDSCAPE ARCHITECT, OR LAND SURVEYOR SHALL STAMP THE DOCUMENT AND INCLUDE THE NOTATION "ALTERED BY" FOLLOWED BY THEIR SIGNATURE, THE DATE OF SUCH ALTERATION, AND A SPECIFIC DESCRIPTION OF THE ALTERATION.

CITY OF PORTSMOUTH CITY OF PORTSMOUTH, NEW HAMPSHIRE			
PEVERLY HILL ROAD RECONSTRUCTION			
SIDEWALK DETAILS (SHEET 2 OF 9)			
REV	DATE	DESCRIPTION	BY
 McFarland Johnson 53 REGIONAL DRIVE CONCORD, NH 03301		SCALE: ---- DRAWN: MJF CHECKED: JWS	DESIGN: MAH PROJECT: 18082.01 DATE: XX/XX/2018 DT-03 ----OF 61

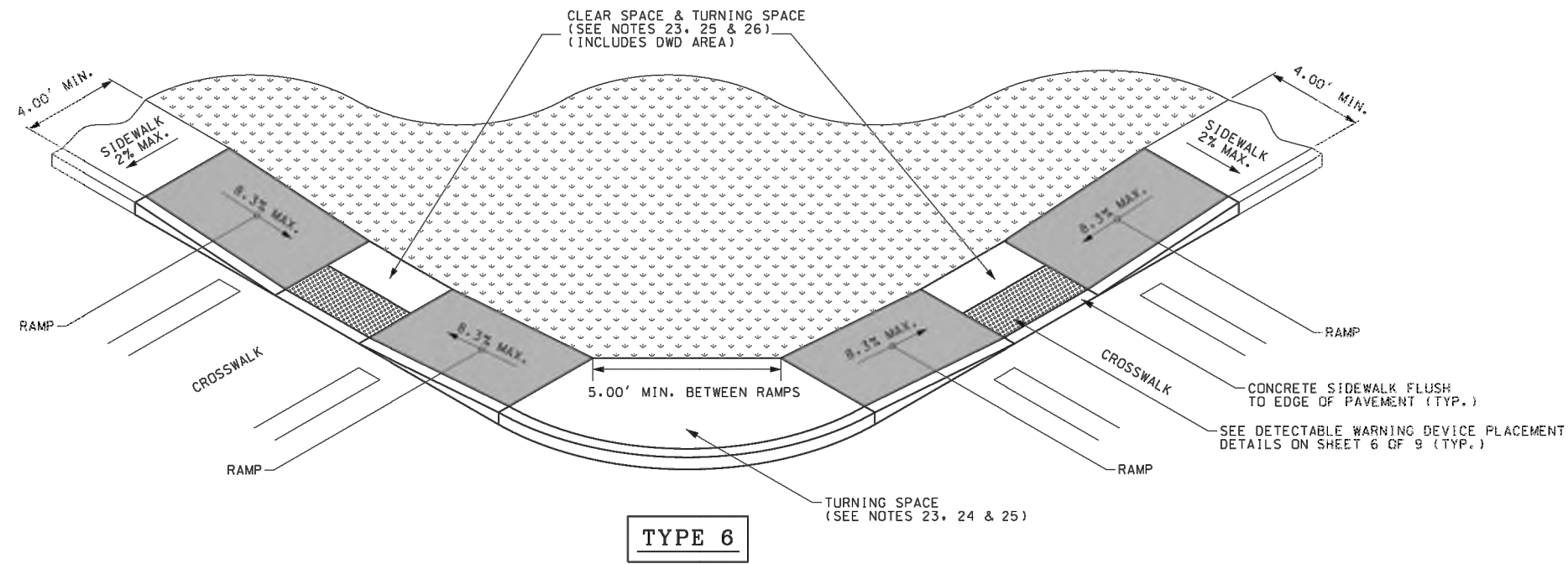

TYPE 6

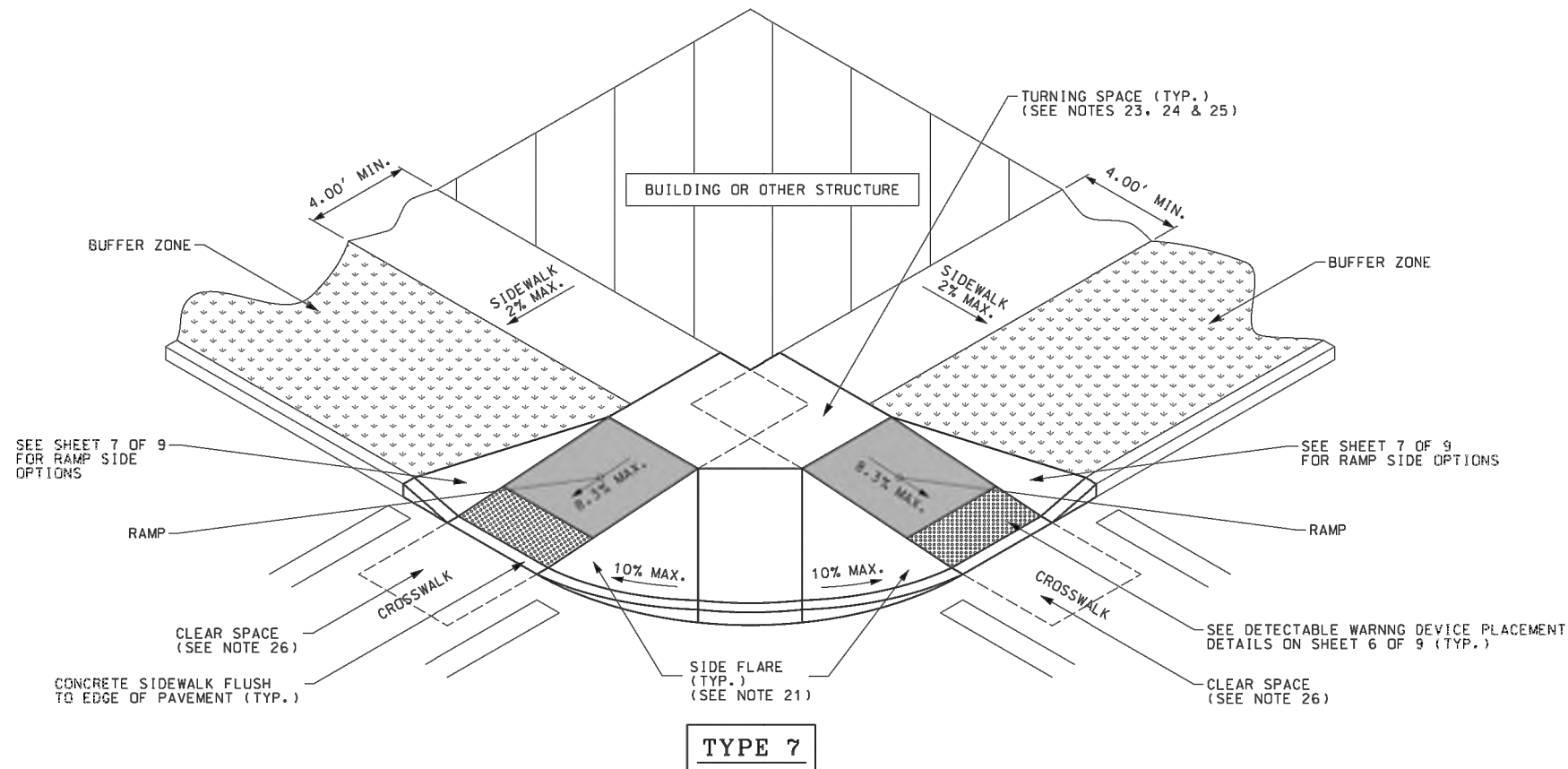

TYPE 7

CURB RAMP CONFIGURATIONS

NOTE:
ALL NOTES REFERENCED ON THIS SHEET CAN BE FOUND ON SIDEWALK CURB RAMP DETAILS, SHEET 1 OF 9.

PRELIMINARY PLANS

IT IS A VIOLATION OF LAW FOR ANY PERSON, UNLESS THEY ARE ACTING UNDER THE DIRECT DIRECTION OF A LICENSED PROFESSIONAL ENGINEER, ARCHITECT, LANDSCAPE ARCHITECT, OR LAND SURVEYOR, TO ALTER AN ITEM IN ANY WAY. IF AN ITEM BEARING THE STAMP OF A LICENSED PROFESSIONAL IS ALTERED, THE ALTERING ENGINEER, ARCHITECT, LANDSCAPE ARCHITECT, OR LAND SURVEYOR SHALL STAMP THE DOCUMENT AND INCLUDE THE NOTATION "ALTERED BY" FOLLOWED BY THEIR SIGNATURE, THE DATE OF SUCH ALTERATION, AND A SPECIFIC DESCRIPTION OF THE ALTERATION.

CITY OF PORTSMOUTH CITY OF PORTSMOUTH, NEW HAMPSHIRE			
PEVERLY HILL ROAD RECONSTRUCTION			
SIDEWALK DETAILS (SHEET 3 OF 9)			
REV	DATE	DESCRIPTION	BY
 McFarland Johnson 53 REGIONAL DRIVE CONCORD, NH 03301		SCALE: ---- DRAWN: MJF CHECKED: JWS	DESIGN: MAH PROJECT: 18082.01 DATE: XX/XX/2018
			DT-04 ---OF 61

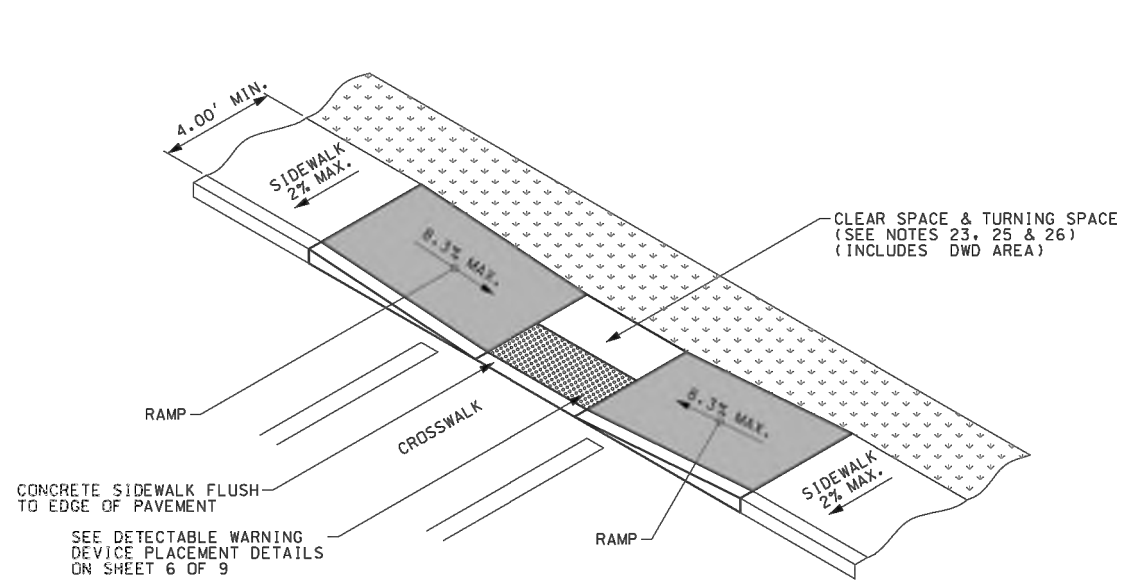

TYPE 8
MID BLOCK CROSSING OR T INTERSECTION

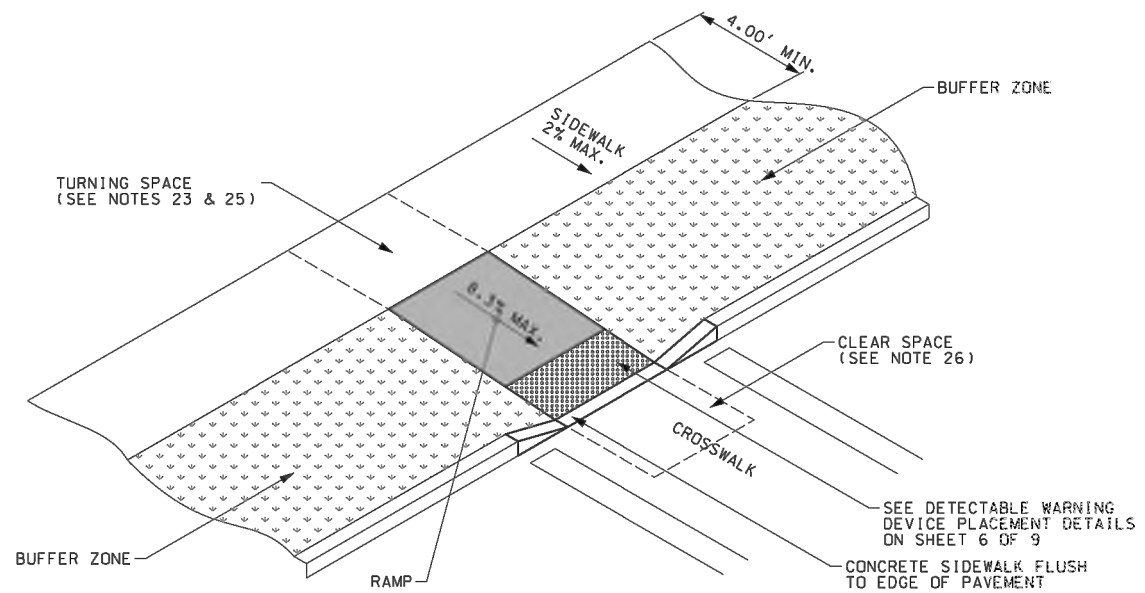

TYPE 10
MID BLOCK CROSSING OR T INTERSECTION

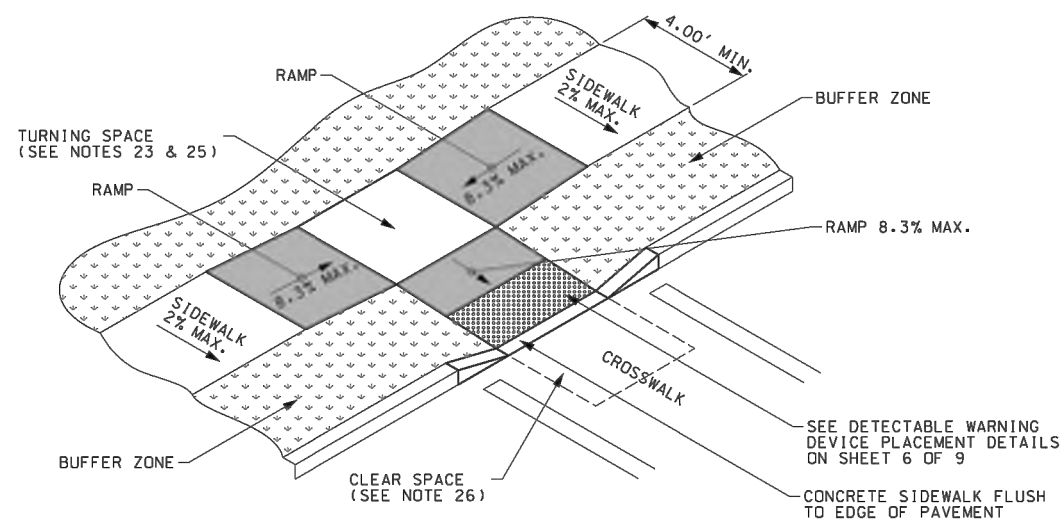

TYPE 9
MID BLOCK CROSSING OR T INTERSECTION

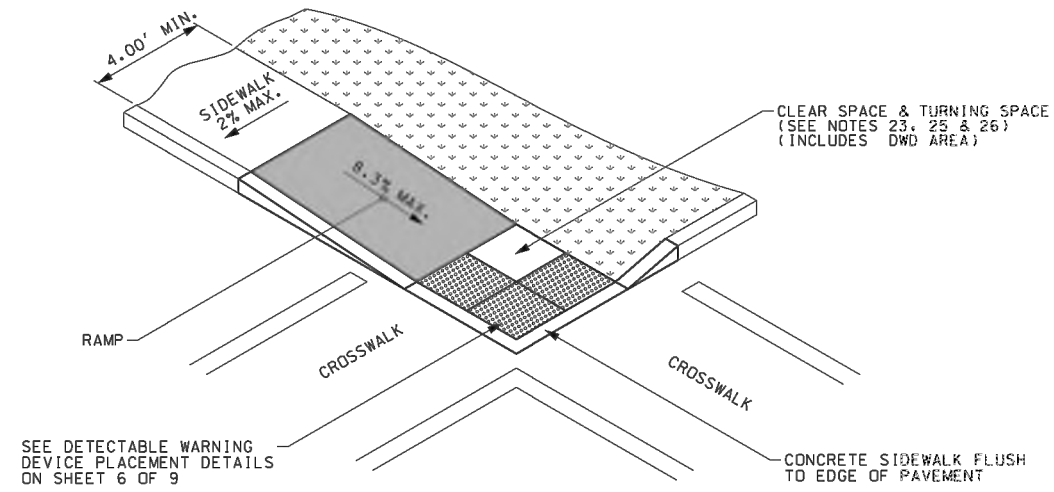

TYPE 11

CURB RAMP CONFIGURATIONS

NOTE:
ALL NOTES REFERENCED ON THIS SHEET CAN BE FOUND ON SIDEWALK CURB RAMP DETAILS, SHEET 1 OF 9.

PRELIMINARY PLANS

IT IS A VIOLATION OF LAW FOR ANY PERSON, UNLESS THEY ARE ACTING UNDER THE DIRECT DIRECTION OF A LICENSED PROFESSIONAL ENGINEER, ARCHITECT, LANDSCAPE ARCHITECT, OR LAND SURVEYOR, TO ALTER AN ITEM IN ANY WAY. IF AN ITEM BEARING THE STAMP OF A LICENSED PROFESSIONAL IS ALTERED, THE ALTERING ENGINEER, ARCHITECT, LANDSCAPE ARCHITECT, OR LAND SURVEYOR SHALL STAMP THE DOCUMENT AND INCLUDE THE NOTATION "ALTERED BY" FOLLOWED BY THEIR SIGNATURE, THE DATE OF SUCH ALTERATION, AND A SPECIFIC DESCRIPTION OF THE ALTERATION.

CITY OF PORTSMOUTH CITY OF PORTSMOUTH, NEW HAMPSHIRE			
PEVERLY HILL ROAD RECONSTRUCTION			
SIDEWALK DETAILS (SHEET 4 OF 9)			
REV	DATE	DESCRIPTION	BY
		McFarland Johnson	
53 REGIONAL DRIVE CONCORD, NH 03301		SCALE: ----	DESIGN: MAH
		DRAWN: MJF	PROJECT: 18082.01
		CHECKED: JWS	DATE: XX/XX/2018
			DT-05 ----OF 61

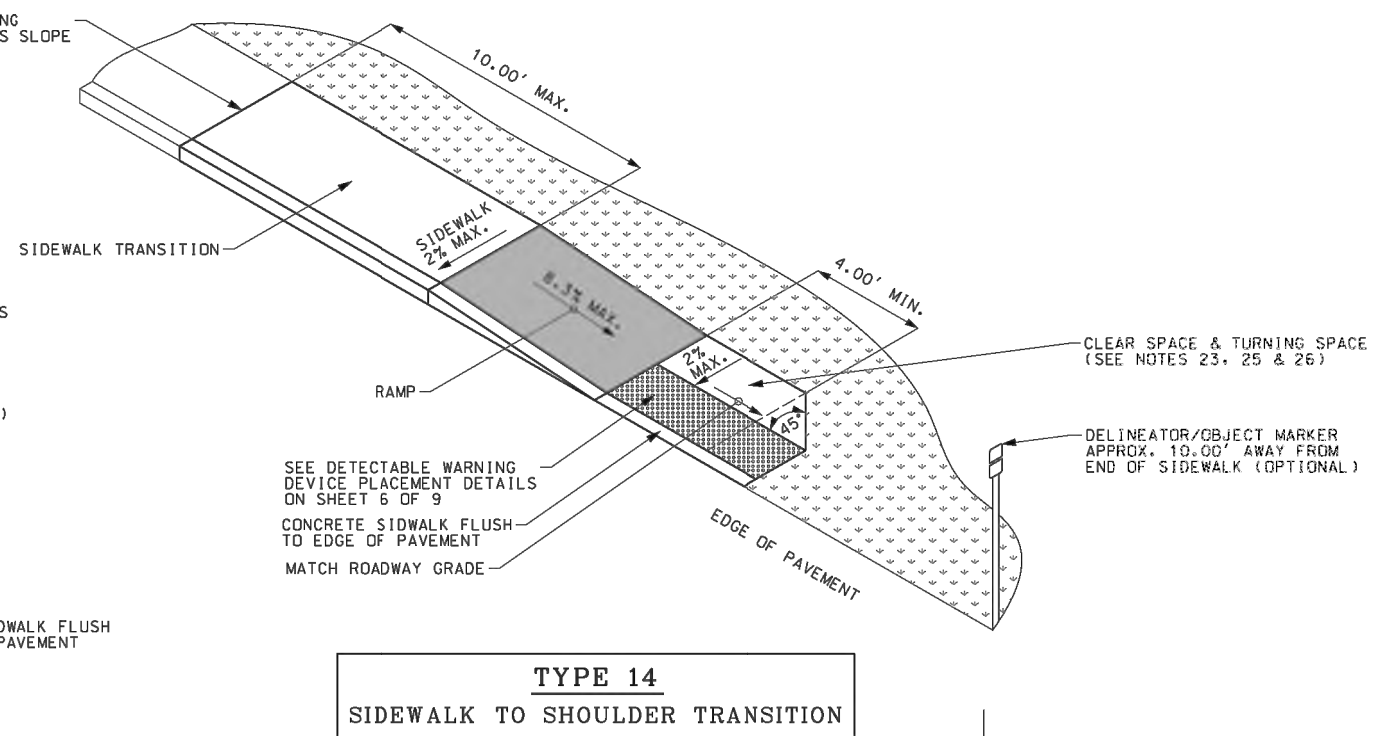
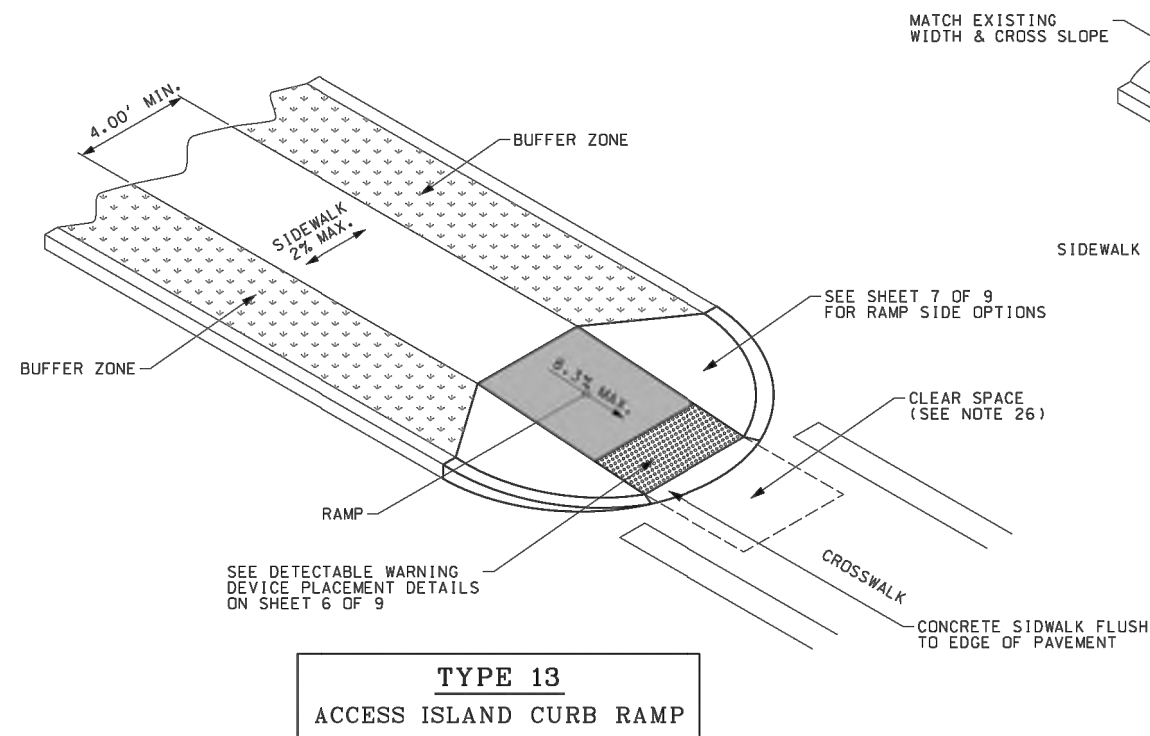
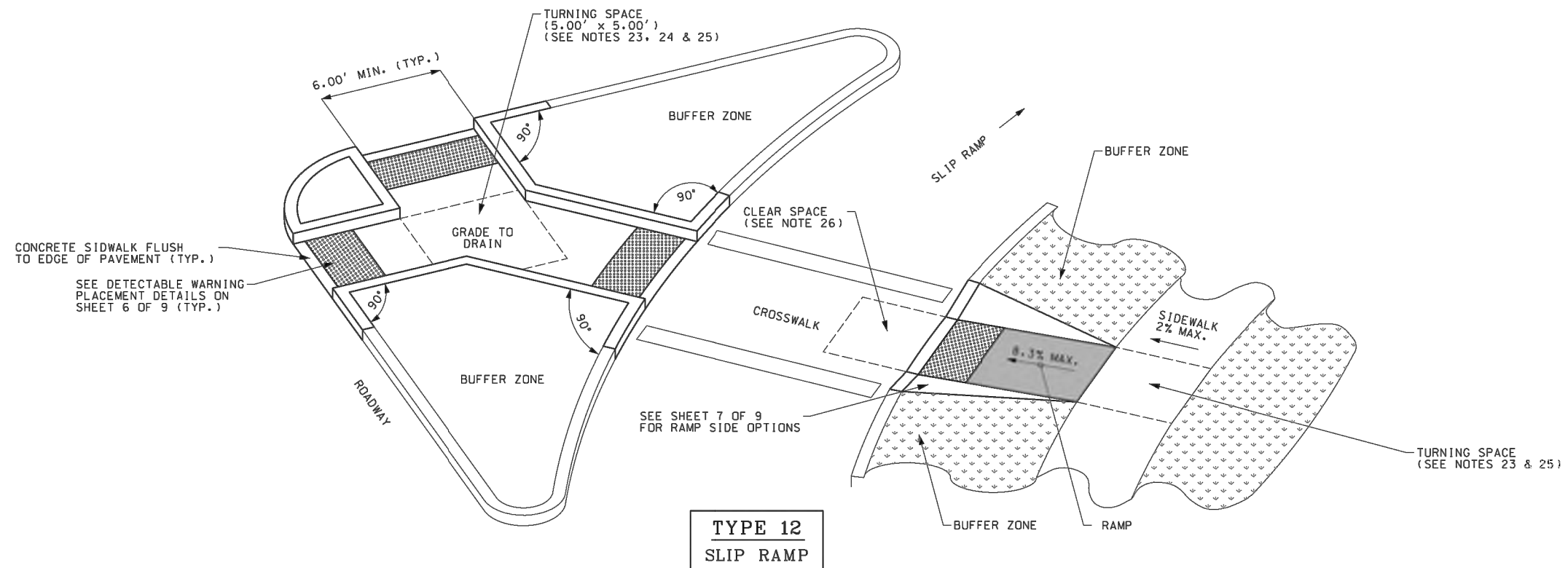

CURB RAMP CONFIGURATIONS

PRELIMINARY PLANS

NOTE:
ALL NOTES REFERENCED ON THIS SHEET CAN BE FOUND ON SIDEWALK CURB RAMP DETAILS, SHEET 1 OF 9.

IT IS A VIOLATION OF LAW FOR ANY PERSON, UNLESS THEY ARE ACTING UNDER THE DIRECT DIRECTION OF A LICENSED PROFESSIONAL ENGINEER, ARCHITECT, LANDSCAPE ARCHITECT, OR LAND SURVEYOR, TO ALTER AN ITEM IN ANY WAY. IF AN ITEM BEARING THE STAMP OF A LICENSED PROFESSIONAL IS ALTERED, THE ALTERING ENGINEER, ARCHITECT, LANDSCAPE ARCHITECT, OR LAND SURVEYOR SHALL STAMP THE DOCUMENT AND INCLUDE THE NOTATION "ALTERED BY" FOLLOWED BY THEIR SIGNATURE, THE DATE OF SUCH ALTERATION, AND A SPECIFIC DESCRIPTION OF THE ALTERATION.

CITY OF PORTSMOUTH CITY OF PORTSMOUTH, NEW HAMPSHIRE			
PEVERLY HILL ROAD RECONSTRUCTION			
SIDEWALK DETAILS (SHEET 5 OF 9)			
REV	DATE	DESCRIPTION	BY
 McFarland Johnson 53 REGIONAL DRIVE CONCORD, NH 03301			
SCALE: ----	DESIGN: MAH	DT-06	
DRAWN: MJF	PROJECT: 18082.01		
CHECKED: JWS	DATE: XX/XX/2018	----OF 61	

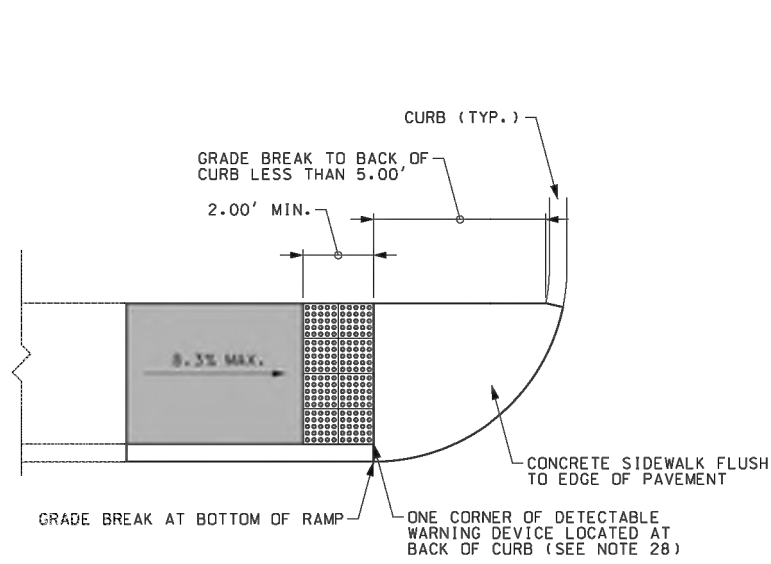

OPTION 1

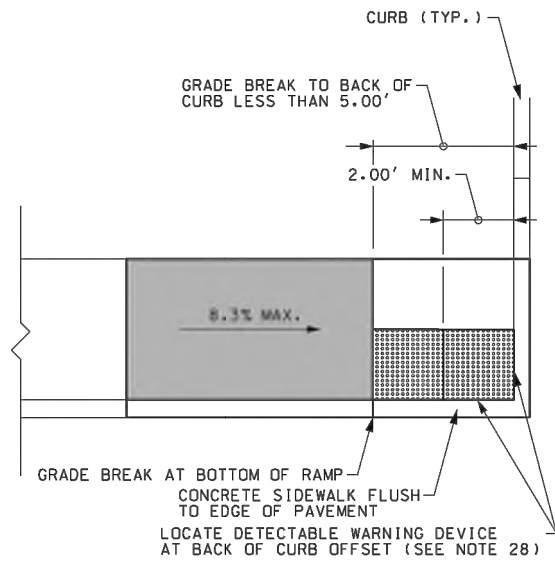

OPTION 2

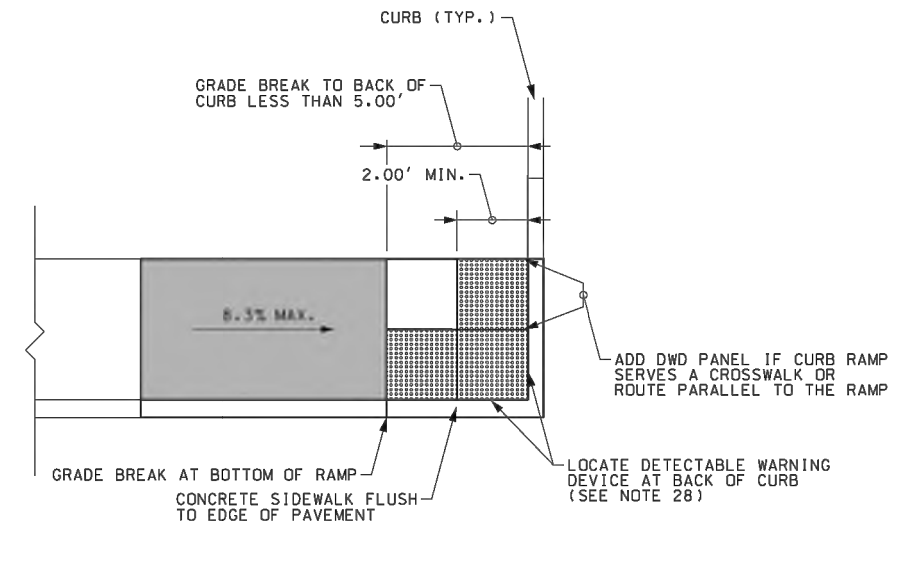

OPTION 2A

GRADE BREAK TO BACK OF CURB LESS THAN 5.00'

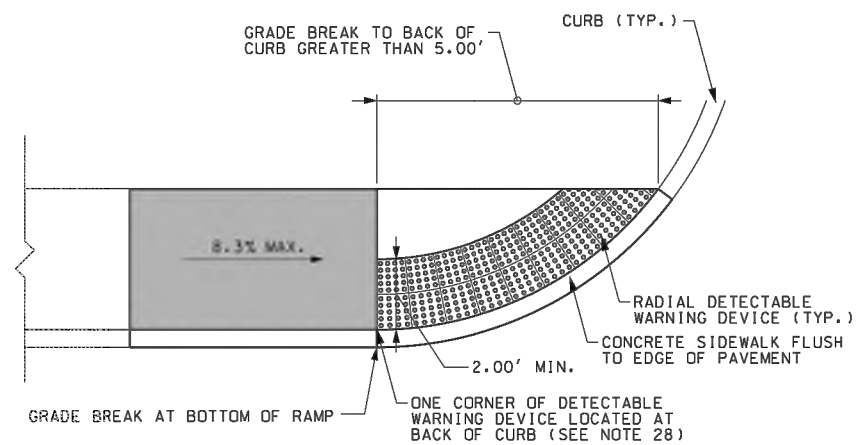

OPTION 3

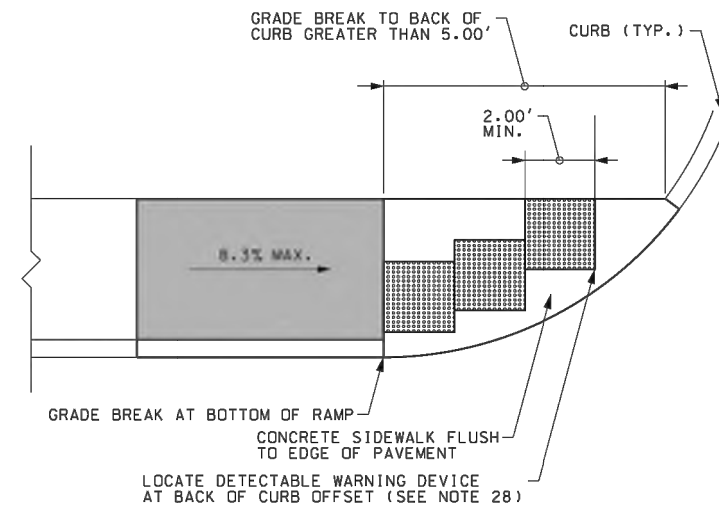

OPTION 4

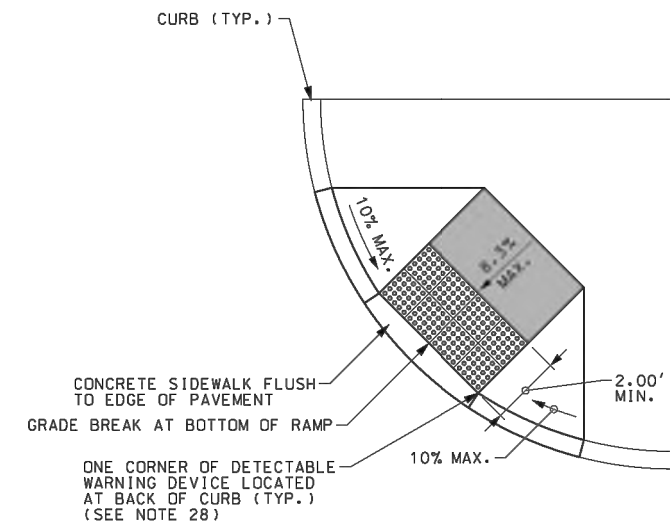

OPTION 5

GRADE BREAK TO BACK OF CURB GREATER THAN 5.00'

PRELIMINARY PLANS

IT IS A VIOLATION OF LAW FOR ANY PERSON, UNLESS THEY ARE ACTING UNDER THE DIRECT DIRECTION OF A LICENSED PROFESSIONAL ENGINEER, ARCHITECT, LANDSCAPE ARCHITECT, OR LAND SURVEYOR, TO ALTER AN ITEM IN ANY WAY. IF AN ITEM BEARING THE STAMP OF A LICENSED PROFESSIONAL IS ALTERED, THE ALTERING ENGINEER, ARCHITECT, LANDSCAPE ARCHITECT, OR LAND SURVEYOR SHALL STAMP THE DOCUMENT AND INCLUDE THE NOTATION "ALTERED BY" FOLLOWED BY THEIR SIGNATURE, THE DATE OF SUCH ALTERATION, AND A SPECIFIC DESCRIPTION OF THE ALTERATION.

CITY OF PORTSMOUTH CITY OF PORTSMOUTH, NEW HAMPSHIRE	
PEVERLY HILL ROAD RECONSTRUCTION	
SIDEWALK DETAILS (SHEET 6 OF 9)	
SCALE: ----	DESIGN: MAH
DRAWN: MJF	PROJECT: 18082.01
CHECKED: JWS	DATE: XX/XX/2018
	DT-07 ----OF 61

McFarland Johnson
53 REGIONAL DRIVE
CONCORD, NH 03301

REV	DATE	DESCRIPTION	BY

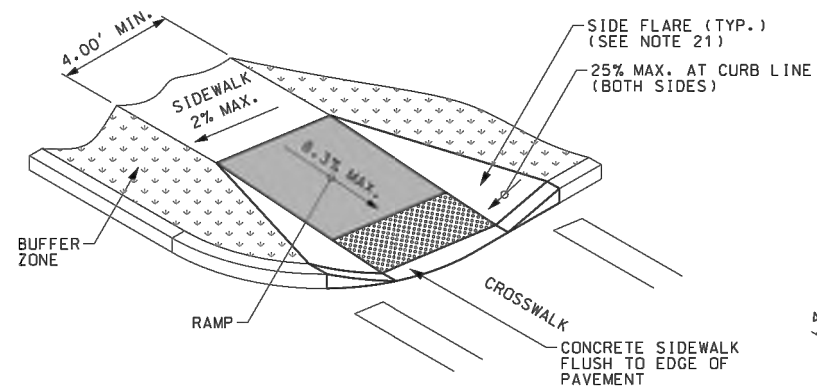

**OPTION A
FLARED CONCRETE**

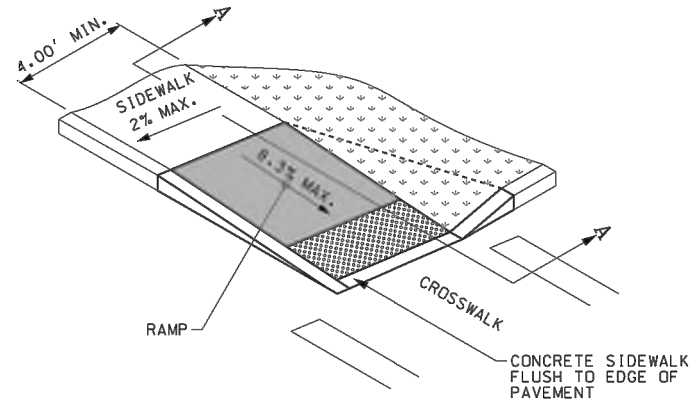

**OPTION B
GRADED EARTH**

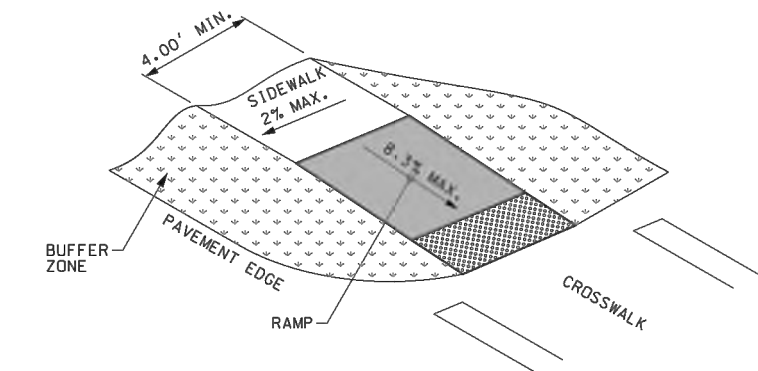

**OPTION C
UNCURBED INTERSECTION**

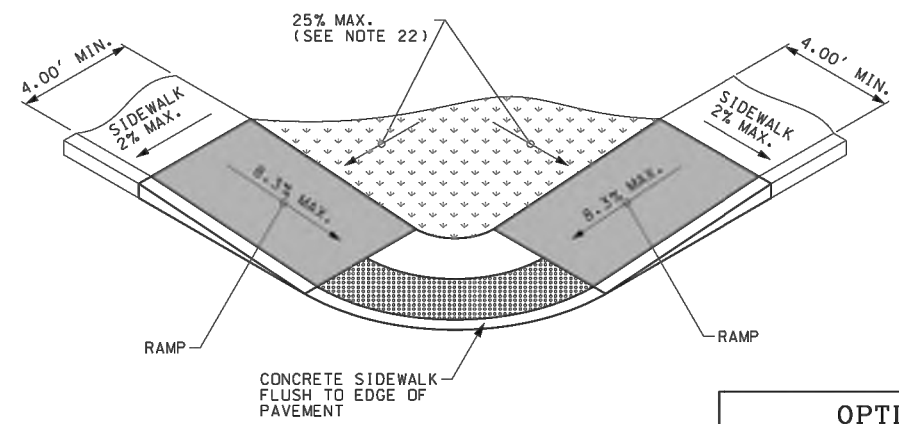

**OPTION A
GRADED EARTH AND TURF**

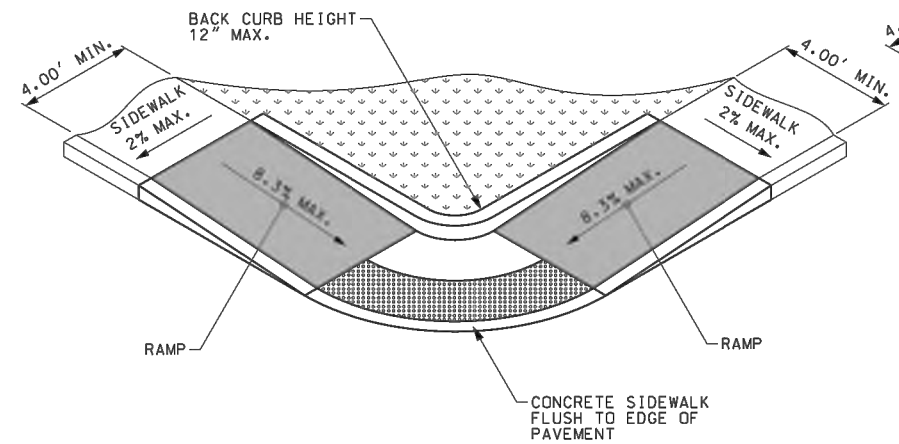

**OPTION B
BACK CURB**

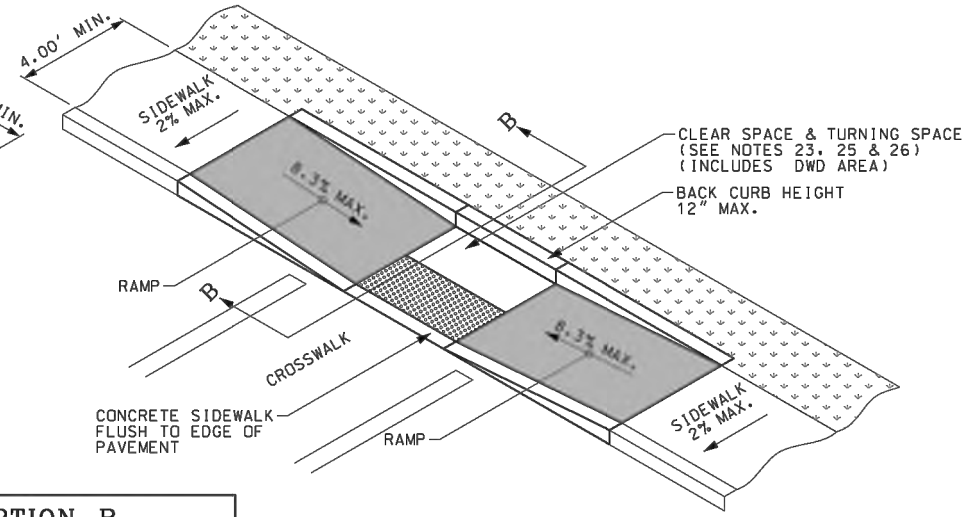
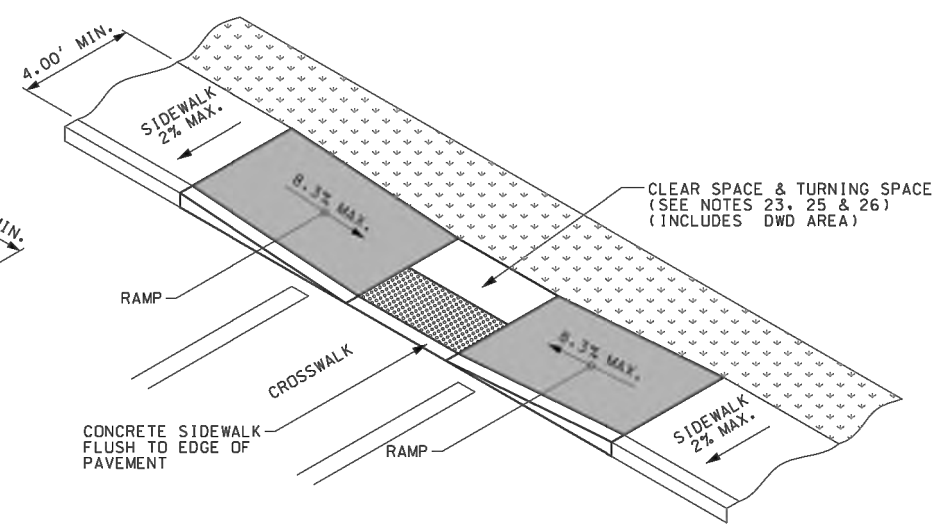

RAMP SIDE CONFIGURATIONS

RAMP BACK TREATMENTS

NOTE:
ALL NOTES REFERENCED ON THIS SHEET CAN BE FOUND ON SIDEWALK CURB RAMP DETAILS, SHEET 1 OF 9.

PRELIMINARY PLANS

IT IS A VIOLATION OF LAW FOR ANY PERSON, UNLESS THEY ARE ACTING UNDER THE DIRECT DIRECTION OF A LICENSED PROFESSIONAL ENGINEER, ARCHITECT, LANDSCAPE ARCHITECT, OR LAND SURVEYOR, TO ALTER AN ITEM IN ANY WAY. IF AN ITEM BEARING THE STAMP OF A LICENSED PROFESSIONAL IS ALTERED, THE ALTERING ENGINEER, ARCHITECT, LANDSCAPE ARCHITECT, OR LAND SURVEYOR SHALL STAMP THE DOCUMENT AND INCLUDE THE NOTATION "ALTERED BY" FOLLOWED BY THEIR SIGNATURE, THE DATE OF SUCH ALTERATION, AND A SPECIFIC DESCRIPTION OF THE ALTERATION.

CITY OF PORTSMOUTH CITY OF PORTSMOUTH, NEW HAMPSHIRE			
PEVERLY HILL ROAD RECONSTRUCTION			
SIDEWALK DETAILS (SHEET 7 OF 9)			
REV	DATE	DESCRIPTION	BY
		McFarland Johnson	
53 REGIONAL DRIVE CONCORD, NH 03301		SCALE: ----	DESIGN: MAH
		DRAWN: MJF	PROJECT: 18082.01
		CHECKED: JWS	DATE: XX/XX/2018
			DT-08 ----OF 61

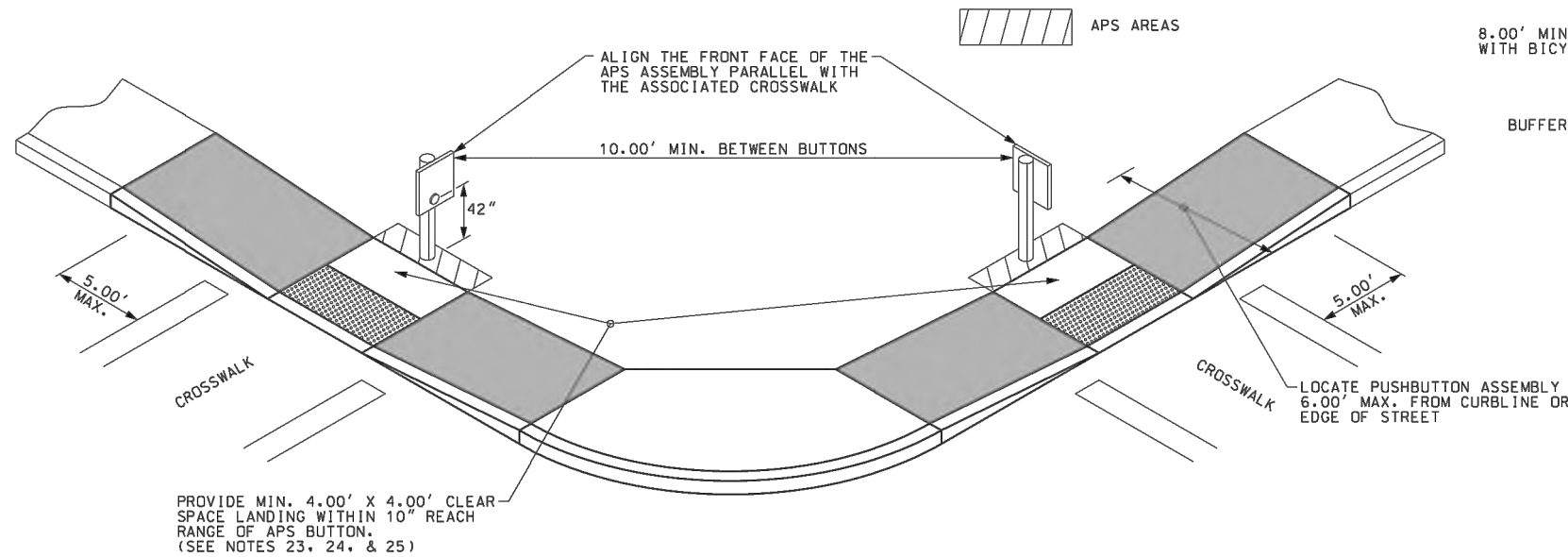

PROVIDE MIN. 4.00' X 4.00' CLEAR SPACE LANDING WITHIN 10\"/>

ACCESSIBLE PEDESTRIAN SIGNAL (APS) PUSHBUTTON LOCATION

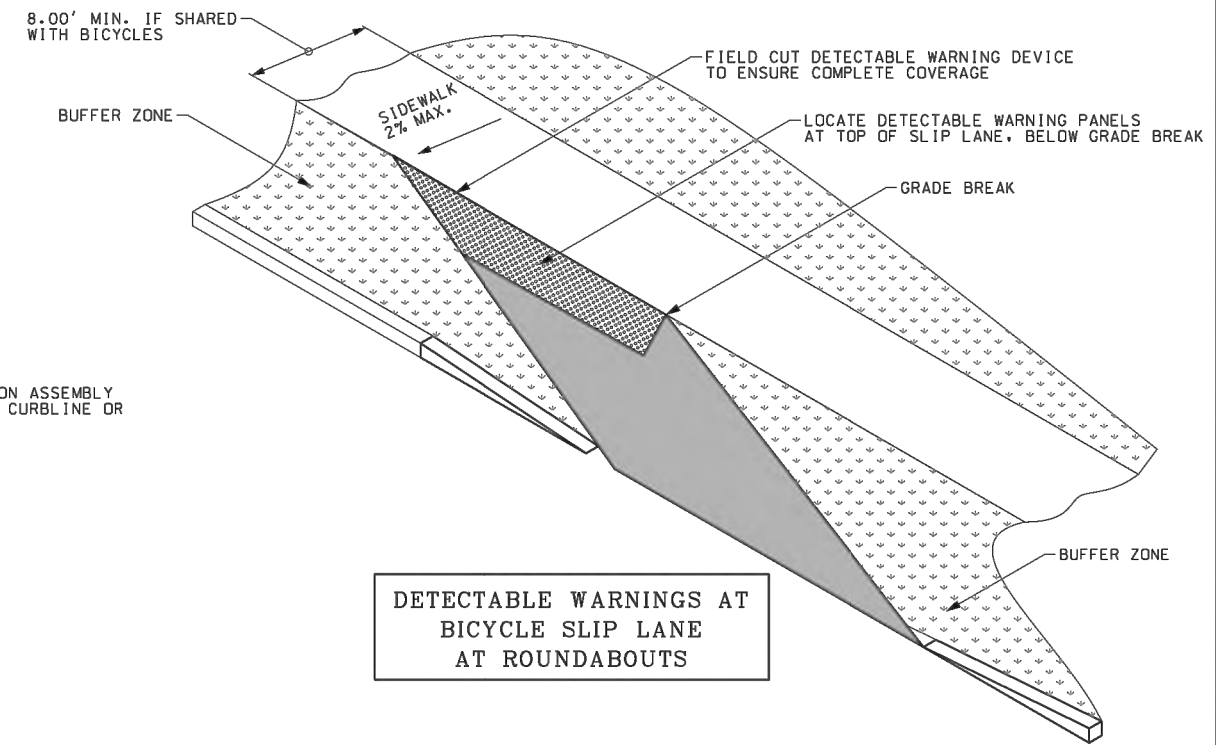

DETECTABLE WARNINGS AT BICYCLE SLIP LANE AT ROUNDABOUTS

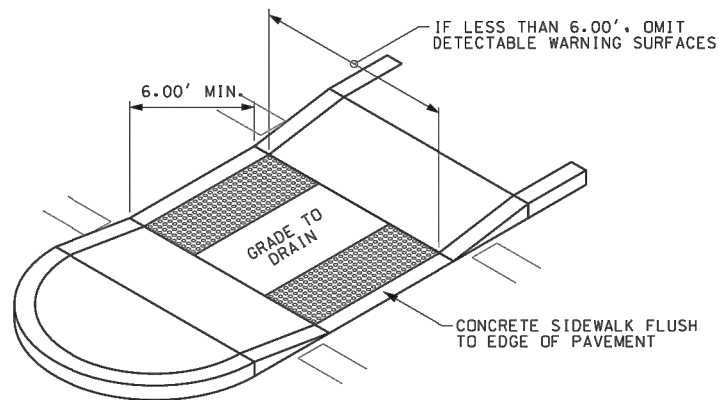

DETECTABLE WARNINGS AT PEDESTRIAN REFUGE ISLANDS

NON-ELEVATED CROSSING

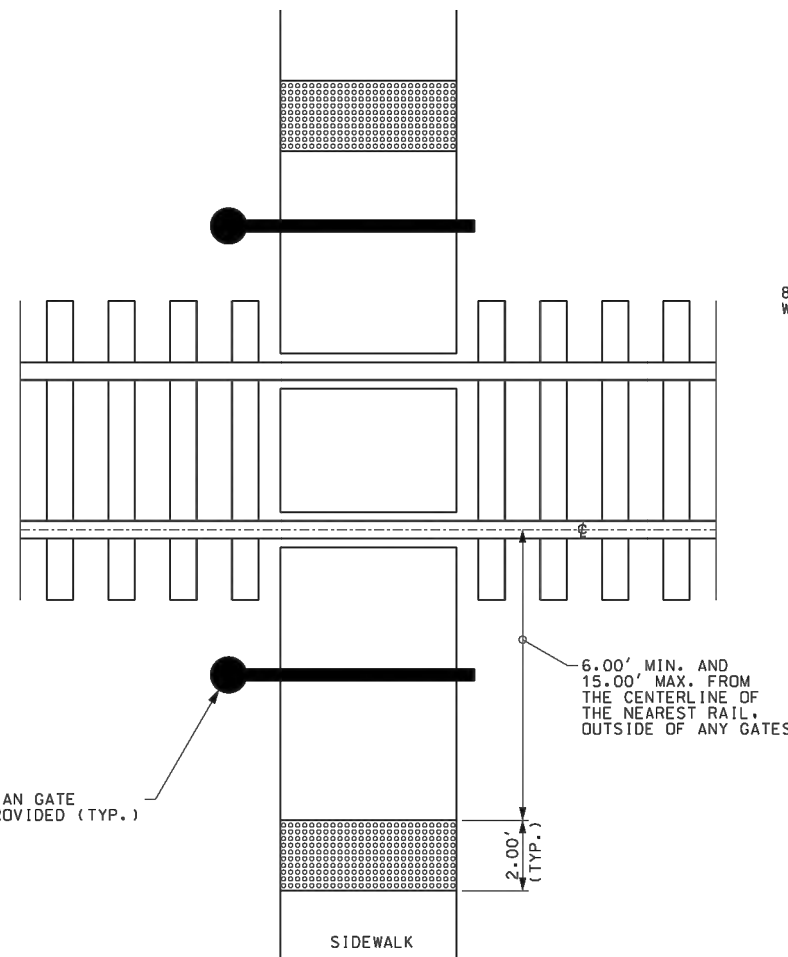

DETECTABLE WARNINGS AT RAILROAD CROSSING

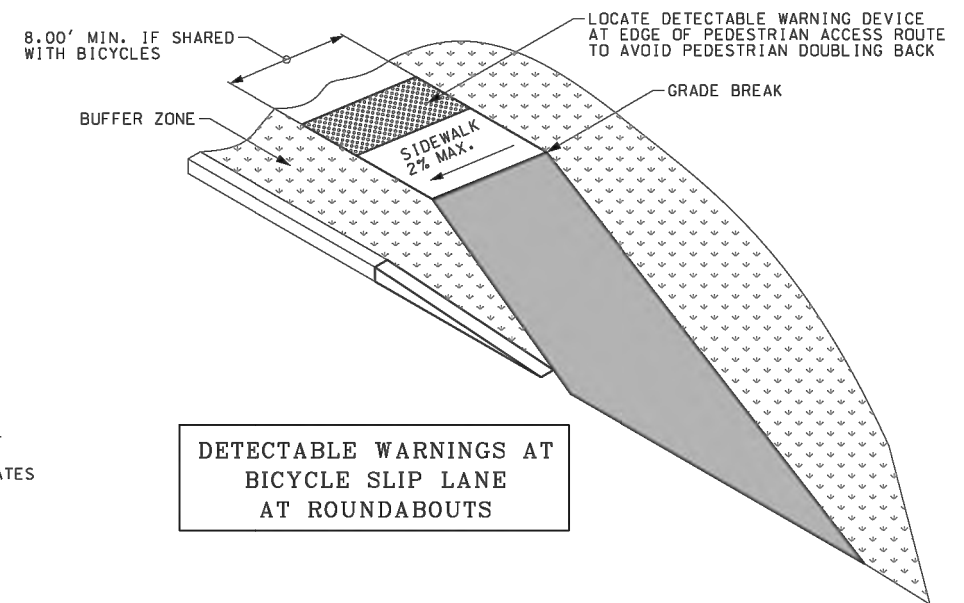

DETECTABLE WARNINGS AT BICYCLE SLIP LANE AT ROUNDABOUTS

NOTE:
ALL NOTES REFERENCED ON THIS SHEET CAN BE FOUND ON SIDEWALK CURB RAMP DETAILS, SHEET 1 OF 9.

PRELIMINARY PLANS

IT IS A VIOLATION OF LAW FOR ANY PERSON, UNLESS THEY ARE ACTING UNDER THE DIRECT DIRECTION OF A LICENSED PROFESSIONAL ENGINEER, ARCHITECT, LANDSCAPE ARCHITECT, OR LAND SURVEYOR, TO ALTER AN ITEM IN ANY WAY. IF AN ITEM BEARING THE STAMP OF A LICENSED PROFESSIONAL IS ALTERED, THE ALTERING ENGINEER, ARCHITECT, LANDSCAPE ARCHITECT, OR LAND SURVEYOR SHALL STAMP THE DOCUMENT AND INCLUDE THE NOTATION "ALTERED BY" FOLLOWED BY THEIR SIGNATURE, THE DATE OF SUCH ALTERATION, AND A SPECIFIC DESCRIPTION OF THE ALTERATION.

CITY OF PORTSMOUTH CITY OF PORTSMOUTH, NEW HAMPSHIRE			
PEVERLY HILL ROAD RECONSTRUCTION			
SIDEWALK DETAILS (SHEET 8 OF 9)			
REV	DATE	DESCRIPTION	BY
		McFarland Johnson	
53 REGIONAL DRIVE CONCORD, NH 03301		SCALE: ----	DESIGN: MAH
		DRAWN: MJF	PROJECT: 18082.01
		CHECKED: JWS	DATE: XX/XX/2018
			DT-09 ----OF 61

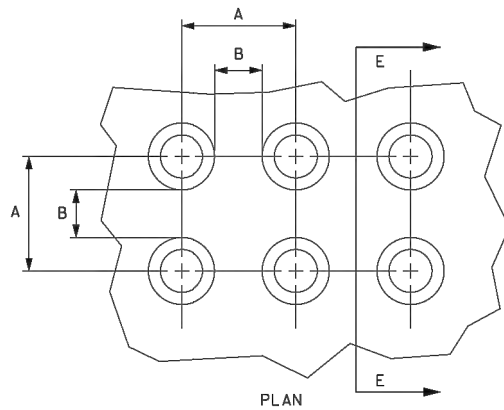

TRUNCATED DOME DIMENSIONS		
DIM.	MIN. (IN)	MAX. (IN)
A	1.6"	2.4"
B	0.65"	1.5"
C	50% - 65% OF D DIM.	
D	0.9"	1.4"

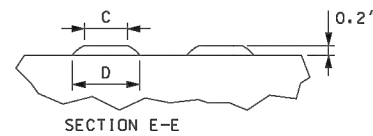

**DETECTABLE WARNING DEVICES (DWD)
TRUNCATED DOME DETAILS**

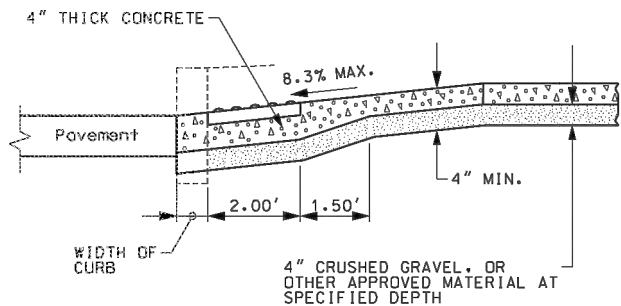

SECTION A-A
SEE SHEET 7 OF 9

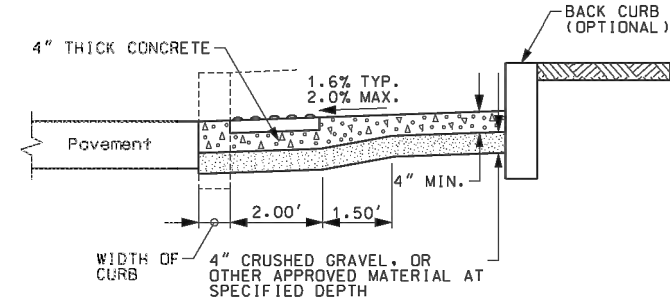

SECTION B-B
SEE SHEET 7 OF 9

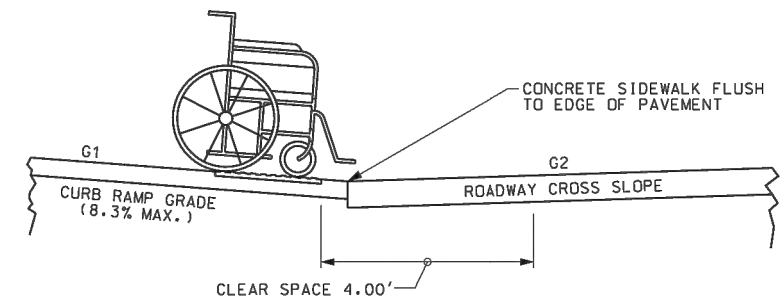

COUNTER SLOPE CONDITION 1

$A = G2 - G1$
ALGEBRAIC DIFFERENCE (A) BETWEEN ROADWAY CROSS SLOPE AND CURB RAMP GRADE IS LESS THAN 13.3%.

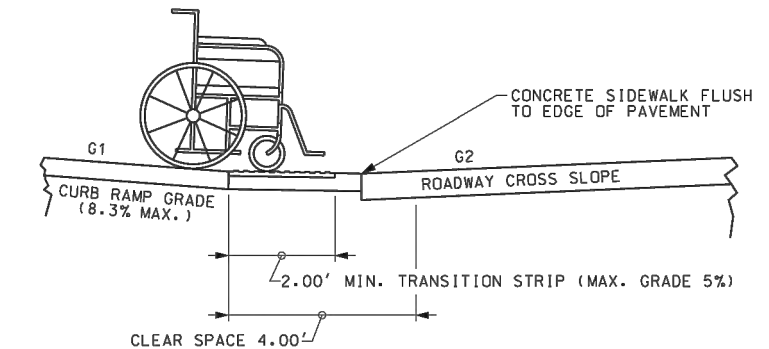

COUNTER SLOPE CONDITION 2

$A = G2 - G1$
ALGEBRAIC DIFFERENCE (A) BETWEEN ROADWAY SLOPE AND CURB RAMP GRADE IS GREATER THAN 13.3%. TRANSITION STRIP REQUIRED (MAX. GRADE 5%)

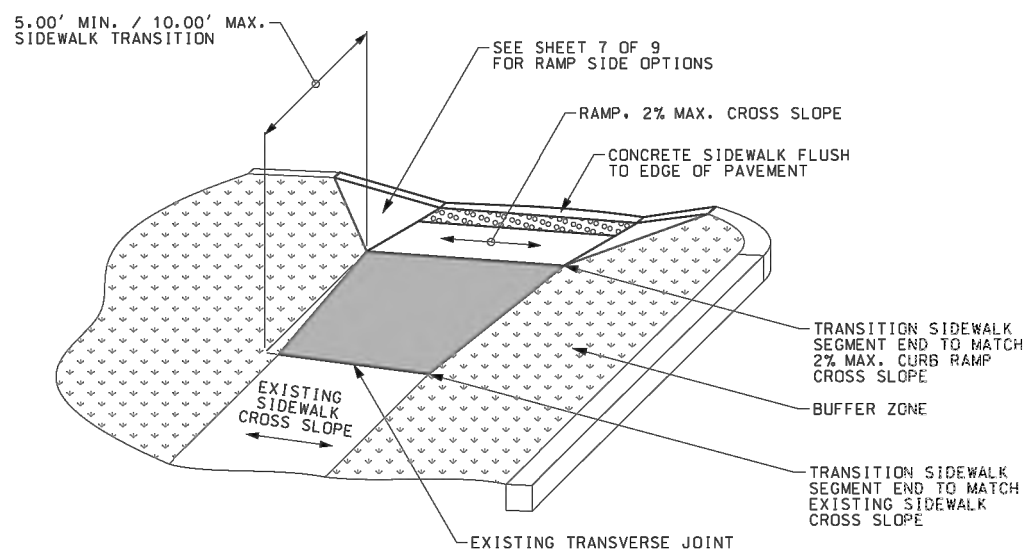

TRANSITION BETWEEN CURB RAMP AND EXISTING SIDEWALK

USE FOR CROSS SLOPE AND WIDTH TRANSITIONS

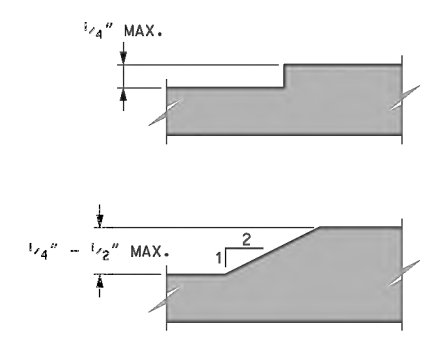

VERTICAL SURFACE DISCONTINUITIES

SEE NOTE 5

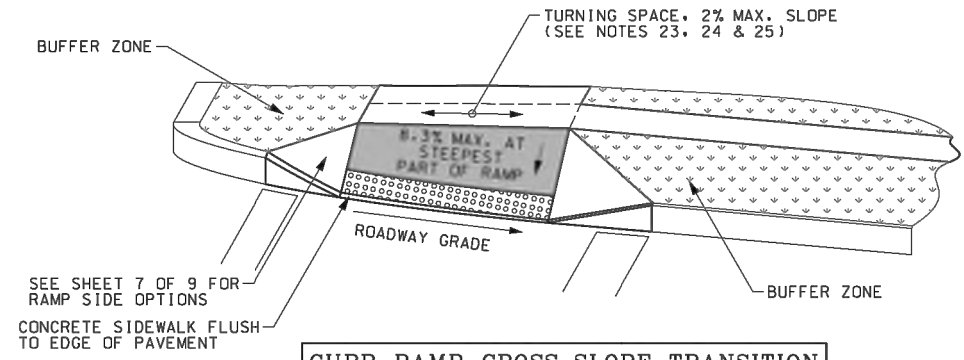

CURB RAMP CROSS SLOPE TRANSITION

REFER TO NOTE 20 FOR CROSS SLOPE REQUIREMENTS

NOTE:
ALL NOTES REFERENCED ON THIS SHEET CAN BE FOUND ON SIDEWALK CURB RAMP DETAILS, SHEET 1 OF 9.

PRELIMINARY PLANS

IT IS A VIOLATION OF LAW FOR ANY PERSON, UNLESS THEY ARE ACTING UNDER THE DIRECT DIRECTION OF A LICENSED PROFESSIONAL ENGINEER, ARCHITECT, LANDSCAPE ARCHITECT, OR LAND SURVEYOR, TO ALTER AN ITEM IN ANY WAY. IF AN ITEM BEARING THE STAMP OF A LICENSED PROFESSIONAL IS ALTERED, THE ALTERING ENGINEER, ARCHITECT, LANDSCAPE ARCHITECT, OR LAND SURVEYOR SHALL STAMP THE DOCUMENT AND INCLUDE THE NOTATION "ALTERED BY" FOLLOWED BY THEIR SIGNATURE, THE DATE OF SUCH ALTERATION, AND A SPECIFIC DESCRIPTION OF THE ALTERATION.

CITY OF PORTSMOUTH CITY OF PORTSMOUTH, NEW HAMPSHIRE			
PEVERLY HILL ROAD RECONSTRUCTION			
SIDEWALK DETAILS			
REV	DATE	DESCRIPTION	BY
McFarland Johnson 53 REGIONAL DRIVE CONCORD, NH 03301			
SCALE: ----	DESIGN: MAH	DT-10 ----OF 61	
DRAWN: MJF	PROJECT: 18082.01		
CHECKED: JWS	DATE: XX/XX/2018		

ITEM #	MUTCD ID #	SIZE OF SIGN		TEXT	NEW SIGNS REQ'D	# OF SIGNS TO BE RESET	SIGN AREA		POSTS PER SIGN					REMARKS
		WIDTH (IN.)	HEIGHT (IN.)				NOM. (SQ. FT.)	TOTAL (SQ. FT.)	BREAKAWAY	STEEL I-BEAM	CONCRETE BASE	3" SQUARE STEEL	U-CHANNEL	
615.0301	R1-1	30	30		3		6.25	18.75					1	WHITE/RED
615.0301	R1-1m	18	18		2		2.25	4.50					1	WHITE/RED
615.0301	R3-4	24	24		1		4.00	4.00					1	BLACK/WHITE/RED
615.0301	R3-8(13)	24	30		2		6.25	12.50					1	BLACK/WHITE
615.0301	R3-8(14)	24	42		1		7.00	7.00					1	BLACK/WHITE
615.0301	R3-8(15)m	30	42		2		7.00	14.00					1	BLACK/WHITE
615.0301	R3-17	24	18		11		3.00	33.00					1	BLACK/WHITE
615.0301	R5-2	24	24		2		4.00	8.00					1	BLACK/WHITE/RED
615.0301	R5-3	24	24		2		4.00	8.00					1	BLACK/WHITE/RED
615.0301	R9-3	24	24		1		4.00	4.00					1	BLACK/WHITE/RED
615.0301	R9-5	12	18		1		1.50	1.50					1	BLACK/WHITE
615.0301	W3-3	30	30		1		6.25	6.25					1	BLACK/YELLOW/RED /GREEN
615.0301	W11-2	36	36		4		9.00	36.00					1	BLACK/FLUORESCENT YELLOW
615.0301	W5-4a	18	18		2		2.25	4.50					1	BLACK/YELLOW
615.0301	D11-1	24	18		1		3.00	3.00					1	BLACK/WHITE
615.0301	S5-2	24	30		2		6.25	12.50					1	BLACK/WHITE

ITEM #	MUTCD ID #	SIZE OF SIGN		TEXT	NEW SIGNS REQ'D	# OF SIGNS TO BE RESET	SIGN AREA		POSTS PER SIGN					REMARKS
		WIDTH (IN.)	HEIGHT (IN.)				NOM. (SQ. FT.)	TOTAL (SQ. FT.)	BREAKAWAY	STEEL I-BEAM	CONCRETE BASE	3" SQUARE STEEL	U-CHANNEL	
615.0301	SP-1	48	42		2		14.00	28.00					2	BLACK/WHITE
615.0301	S3-1	36	36		2		9.00	18.00					1	BLACK/FLUORESCENT YELLOW
615.0601	R3-17aP	24	8		2		1.33	2.66						BLACK/WHITE
615.0601	R3-17bP	24	8		3		1.33	4.00						BLACK/WHITE
615.0601	R4-7	24	30		1		5.00	5.00						BLACK/WHITE
615.0601	W16-7p	24	12		4		2.00	8.00						BLACK/YELLOW
615.0601	W14-1a	36	8		1		2.00	1.00						BLACK/YELLOW DOUBLE SIDED SIGN
615.0601	M6-1	21	15		5		2.19	10.95						BLACK/WHITE
615.0601	D3-1	54	12		1		4.50	4.50						WHITE/GREEN
615.0601	D3-1	36	12		1		3.00	3.00						WHITE/GREEN
615.0601	D3-1	54	12		1		4.50	4.50						WHITE/GREEN
615.0601	R4-11	30	30		1		6.25	6.25						BLACK/WHITE

GENERAL NOTES:

1. ALL REGULATORY AND WARNING SIGNS SHALL HAVE TYPE VII BACKGROUND SHEETING ("DIAMOND GRADE") UNLESS OTHERWISE SPECIFIED REFER TO STANDARD HIGHWAY SIGNS MANUAL PUBLISHED BY THE USDOT-FHWA FOR EXACT DETAILS OF BORDERS ETC. REFER TO NHDOT STANDARD PLANS FOR ROAD AND BRIDGE CONSTRUCTION FOR EXACT DETAILS OF PERMANENT SIGNING STANDARDS.
2. ALL SIGN HEIGHTS SHALL BE IN ACCORDANCE WITH MANUAL OF UNIFORM TRAFFIC CONTROL DEVICE (MUTCD) STANDARDS, MOST RECENT EDITION.
3. CONTRACTOR SHALL PROVIDE SIGN SHOP DRAWINGS FOR SP-1 SIGN FOR REVIEW AND APPROVAL PRIOR TO THE START OF FABRICATION.

PRELIMINARY PLANS

IT IS A VIOLATION OF LAW FOR ANY PERSON, UNLESS THEY ARE ACTING UNDER THE DIRECT DIRECTION OF A LICENSED PROFESSIONAL ENGINEER, ARCHITECT, LANDSCAPE ARCHITECT, OR LAND SURVEYOR, TO ALTER AN ITEM IN ANY WAY. IF AN ITEM BEARING THE STAMP OF A LICENSED PROFESSIONAL IS ALTERED, THE ALTERING ENGINEER, ARCHITECT, LANDSCAPE ARCHITECT, OR LAND SURVEYOR SHALL STAMP THE DOCUMENT AND INCLUDE THE NOTATION "ALTERED BY" FOLLOWED BY THEIR SIGNATURE, THE DATE OF SUCH ALTERATION, AND A SPECIFIC DESCRIPTION OF THE ALTERATION.

CITY OF PORTSMOUTH CITY OF PORTSMOUTH, NEW HAMPSHIRE			
PEVERLY HILL ROAD RECONSTRUCTION			
SIGN SUMMARY			
REV	DATE	DESCRIPTION	BY
McFarland Johnson 53 REGIONAL DRIVE CONCORD, NH 03301			
SCALE:	DESIGN:	MAH	MK-10 41 OF 50
DRAWN:	MJF	PROJECT: 18082.01	
CHECKED:	BRC	DATE: 09/08/2021	